



Proceedings of the SAWA-Mid-term Conference in Gothenburg

Berichte des Landesbetriebes Straßen, Brücken und Gewässer
Nr. 5/2010

Sweden 25–27 May 2010



**Proceedings of the SAWA-Mid-term Conference Gothenburg,
Sweden 25 – 27 May 2010**

Table of contents

Foreword in German Hans-Jochen Hinz	4
Foreword Hans-Jochen Hinz	5
Foreword Lars Bäckström	7
PFRA, the Norwegian approach	10
Methodologies to Assess and Map Flood Risk	12
On the Way to a Flood Risk Management Plan	14
How to use existing Flood Risk Managements plans for the Flood directive	16
Climate change projections and flood risk management	18
Wiki Catalogue of Measures Concept	22
Meaningful Stakeholder Engagement	24
FD – WFD Synergetic Measures	26
Managing Urban Creep	28
Every calamity asks for decisions	30
Sustainable Flood Retention Basins (SFRB) as Adaptive Measures	32
Sustainability Education Centres – general information and Dutch examples	36
Integrating education, collaboration and research in teaching methods – A Swedish concept	38
SAWA's Academic Network – Joint Forces for a new University program on Flood Risk Management	40
3-Weir-Regulation	44
Hamburg University of Technology	46
Leuphana University of Lueneburg	48
Agriculture Chamber of Lower Saxony	50
Waterschap Hunze en Aa's, The Netherlands	52
Waterboard of Delfland	54
Every calamity asks for decisions	55
Green roofs as measure for urban flood reduction	56
Rain gardens for urban flood reduction	58
Catchment area – what we do	58
Climate change and flood risk management in Norway	60
Municipality of Melhus, Norway	62
The County Administrative Board of Värmland, Sweden	64
The Swedish Meteorological and Hydrological Institute	66
The County Administrative Board of Västra Götaland, Sweden	68
Karlstad University, Sweden	70
Swedish Geotechnical Institute, SGI	72
Heriot-Watt University	74
Institute for Infrastructure and Environment, The University of Edinburgh	76
Acknowledgements	78
Imprint	80

Foreword in German Hans-Jochen Hinz



Wie in Hamburg sind in vielen Gebieten Europas hochwertig genutzte Gebiete durch Hochwasser bedroht. Beispiele der jüngsten Vergangenheit von Überflutungen sind uns allen vor Augen. Die Probleme werden sich künftig wohl noch verschärfen, wenn der Klimawandel den Niederschlagscharakter verschärft.

Zur Anpassung an die Folgen des Klimawandels arbeiten Hamburgische Behörden und Institutionen mit Partnern in Europa zusammen, intensiv, fruchtbar – und mit einem transnationalen Ansatz und erfüllen damit die gesetzlichen Aufgaben der EU Hochwasserrisikomanagement-Richtlinie.

Seit den späten 90er Jahren gibt es das EU-Programm INTERREG an dem auch Hamburg teilnimmt. Ziel des Programms ist es, durch transnationales Herangehen an gemeinsame Herausforderungen bessere Lösungen zu entwickeln, als dies einzeln möglich wäre. Dabei tauschen die INTERREG-Programtteilnehmer ihre Erfahrungen intensiv aus, ziehen gegenseitigen Nutzen daraus und lösen gemeinschaftlich anstehende Aufgaben. So wächst Europa weiter zusammen. Brüssel fördert diese Art der Zusammenarbeit aus dem Europäischen Fonds für regionale Entwicklung (EFRE).

Im Mai 2008 ist der Antrag des Landesbetriebes Straßen, Brücken und Gewässer (LSBG) für das Projekt SAWA (Strategic Alliance for integrated Water management Actions) für eine Förderung über das Interreg IVB Programm der Nordseeregionen angenommen worden. Unter der Leitung des LSBG entwickeln 22 Partner aus Ministerien, Städten, Landkreisen, Behörden, Universitäten und wissenschaftlichen Instituten aus 5 Nordsee-Anrainer-Staaten eine anpassungsfähige Strategie zur Umsetzung der EG-Hochwasserrisikomanagement-Richtlinie im Einklang mit der bestehenden EG-Wasser-Rahmenrichtlinie.

Die vorliegenden „Proceedings of the SAWA Mid-Term-Conference“ markieren einen Meilenstein im Projekt SAWA. Zur Halbzeit ist es angebracht einen Blick zurück zu werfen und einen Abgleich zu machen zwischen der ursprünglichen Zielsetzung mit dem bisher Erreichten. Dieser Abgleich dient auch der Zielanpassung für die zweite Hälfte der Projektlaufzeit.

Die Beiträge zeigen, dass SAWA auf einem guten Weg ist. Die Vielfalt, Innovation, Motivation und Kooperation ist klar zu erkennen. Die gesetzten Ziele werden verfolgt und werden am Ende erfolgreich in eine anpassungsfähige Strategie für den Umgang mit den Herausforderungen des Klimawandels und des Hochwasserschutzes münden.

Ich wünsche den SAWA-Partnern und der Projektleitung weiter viel Erfolg und auch Spaß in der Zusammenarbeit.

Hans-Jochen Hinz

Geschäftsführer des Landesbetriebes Straßen, Brücken und Gewässer
Behörde für Stadtentwicklung und Umwelt der Freien und Hansestadt Hamburg

Foreword Hans-Jochen Hinz

Like Hamburg many other high class used areas in Europe are threatened by floods. The recent examples of flooding are well in mind. The problems will exacerbate in the future if the climate change intensifies the character of precipitation.

To adapt to the impacts of climate change Hamburg authorities and institutions work, together with partners in Europe, intensely, fruitful, and with a transnational approach, and thus fulfil the statutory duties of the EU Flood Risk Management Policy.

Since the late 90s, there is the EU program INTERREG in which Hamburg also participates. The program aims to develop better solutions by tackling common challenges with a transnational approach, than it would be possible individually. In the INTERREG program participants share their experiences intensively; they draw mutual benefit from it and solve next upcoming common tasks. Thus Europe is getting together. Brussels promotes this type of cooperation with funds from the European Regional Development Fund (ERDF).

In May 2008 the application of the project SAWA submitted by the Agency of Roads, Bridges was approved for funding in the Interreg IVB Program of the North Sea Region. Under the Leadership of the LSBG 22 partners (ministries, cities, districts, agencies, universities and scientific institutes) from five riparian North Sea Regions are developing an adaptive strategy to implement the Flood Directive in accordance with the Water Framework Directive.

These Proceedings of the SAWA Mid-Term Conference are marking a milestone in the project SAWA

At halftime, it is appropriate to take a look back and make a comparison between the original objectives with the achievement. This balance is useful for the adjustment of the second half of the project. These contributions are showing that SAWA is on a good way. The diversity, innovation, motivation and cooperation are clearly understood. The objectives will be followed and will end successfully in an adaptive strategy to deal with the challenges of climate change and flood protection.

I wish the SAWA partners and the project management team continuously success and fun in the co-operation.

Hans-Jochen Hinz
Director Agency of Roads, Bridges and Water
Ministry of Urban Development and Environment, Free
and Hanseatic City of Hamburg

Foreword Lars Bäckström



High water levels due to heavy rain and snowmelt are natural processes that throughout history, periodically have put nature and man to the test. The issue of flooding and its effects have got an increased actuality with factors such as a growing population, a strong trend of urbanization, increasingly complex and vulnerable communities and

the threat of climate change. Although there is considerable uncertainty surrounding the issue of what to expect from climate change when it comes to details the trend is clear. Most scientists agree upon the fact that a more intense hydrological cycle will be an effect of climate change, meaning that dry areas will be dryer and wet areas will be even wetter. We must therefore adapt our society to better cope with this type of climate change stress. To start this adaptation process the County Administrative boards in year 2009 was given an explicit responsibility to work with climate adaptation regionally. The issues involved in the SAWA project:

- » Identifying technical, social and environmental consequences of floodings
- » Measures to be taken to minor these consequences
- » Communication and capacity building around flooding and climate change

are all highly relevant issues in the general climate adaption work. The outcome of SAWA is therefore also highly relevant to the continuous work at the County Administrative board.

Gothenburg is the second largest city in Sweden, an important logistic centre in the western part of Scandinavia and home for about half a million people. The city is beautifully situated at the west coast, just at the mouth of the Göta river (the largest river in Sweden). The city faces big challenges in finding a way to adapt to a rising sea level, more frequent floodings and at the same time finding room to develop the city. However, the threats have increased the awareness and the city of Gothenburg is today one of the cities in Sweden that have come the furthest in the climate adaptation work. Therefore it's a perfect fit to have the mid term conference of SAWA in the city of Gothenburg.

Lars Bäckström

Sincerely Lars Bäckström, Governor of the County Administrative Board of Västra Götaland

**SAWA's approaches to the implementation
of the EC Flood Directive**

PFRA, the Norwegian approach.

Ivar Olaf Peereboom, Norwegian Water Resources and Energy Directorate (NVE), iope@nve.no

Introduction

The Norwegian Water Resources and Energy Directorate (NVE) is the responsible authority concerning river related management and responsible for implementing EU's flood directive. After a damaging flood in 1995 NVE developed a guideline for land use planning in areas at risk of flooding.

The revised guideline of 2007 stipulates the assessment of flood risk on all 3 levels of the urban planning process. The following procedure is now recommended:

- » Municipal plan: potential hazard should be identified
- » Zoning plan: the actual hazard should be described and risk quantified
- » Building case: a satisfactory level of safety must be documented

Flood inundation maps, resulting from NVE's flood mapping program, provide detailed information to be used in both building cases and zoning plans. To help municipalities identifying potential hazard for flooding it was decided to undertake a small scale national flood risk mapping. This mapping will provide an overview that can also be used for implementing the EU flood Directive – the Preliminary Flood Risk Assessment.

Flood Susceptibility mapping

Norway is a large country when different water related phenomena are to be mapped at a national scale. The total area of Norway is 324,220 km² with nearly a million lakes and approximately 410,000 km of rivers and streams. Modeling the watercourses the traditional way was not an option for flood susceptibility mapping. It was decided to develop a much more simple GIS based method using statistical analysis of hydraulic data from gauging stations from the national hydrologic database (HYDRA). A statistical relation was derived from runoff and field parameters (catchment area). Applying this in a GIS, water levels were calculated along the river courses. From a Digital Elevation Model (DEM 25*25m) the catchment was calculated for each river stretch. Within these the flood level plane was calculated using a special technique where cross sections are simulated by calculating runoff on a virtual terrain model based on the buffer distance along the river. Inundated areas were calculated by overlaying the flood level plane with the DEM.

Preliminary Risk Assessment

The principle behind the use of susceptibility maps in a preliminary risk assessment comes from the way in which risk in hazard areas is normally described:

$$\text{Probability} * \text{Consequence} = \text{Risk}$$

Susceptibility maps are however no hazard maps. Being sort of a "worst case" approach the probability is assumed to be same everywhere. Preliminary Risk in susceptibility areas can therefore be described as:

$$\text{Consequence} = \text{Preliminary Risk}$$

Premises

3 criteria were set with which the preliminary risk assessment must comply. The method must be:

1 Scalable

The aim of the preliminary flood risk assessment is to find areas with significant risk. It is up to the national authorities to decide what is deemed significant risk. This makes it a political issue. To help the decision makers a number of different preliminary risk maps will be produced by using different ways of reclassifying the consequences into risk classes (very high, high, medium, low, very low).

2 Reusable

Norway's mountainous terrain is, beside floods, prone to various types of avalanches such as land slides, rock fall, debris flows and snow avalanches. Snow avalanche and rock fall susceptibility maps were produced by NGU recently, while a method for land slides is under development. The chosen risk assessment method must be independent of the kind of susceptibility map.

3 Simple

The 2 criteria above alone make that the whole method including the scaling must be transparent and easy to understand. Examples from PFRA pilot studies from the European mainland gives an overall picture of very complex assessments using a wide range of indicator with different weight ratios to describe the risk on a receptor group. This is logical considering the scale and severity of flood events. In most cases the effects of floods in Norway are of a completely different size. Being sparsely populated as it is, most of the flood event will "only" affect a handful of houses. This on one hand will be reflected in what is considered "significant". But it should also be affected in the effort undertaken to do the preliminary flood risk assessment.

Method

The Floods Directive Stipulates the following risk receptors to be assessed:

Human; Economy; Environment; Cultural heritage

Human Consequences.

Looking back at the premises we set we decided to use the national address database with the amount of inhabitants per address of the Norwegian Statistical Bureau (SSB). Being a sort of worst case scenario we added indicative numbers of persons related to different buildings such as schools, hospitals, shopping centers, etc. Combining this with the susceptibility maps we find both location and amount of people at risk (potential).

Economic Consequences.

Building costs, weighted for different types, for both buildings and infrastructure are used to assess the economic consequences of an event.

For Cultural heritage and Environment a method is not yet fully developed. The data to be used for these to receptors are the national Cultural heritage database "Askeladden" and the IPPC database.

Methodologies to Assess and Map Flood Risk

To be presented at the SAWA mid term conference by Johan Mannheimer, County Administrative Board of Värmland and Susanna Hogdin, County Administrative Board of Västra Götaland

Purpose of the Flood hazard and Flood Risk Maps

The purpose of risk maps is to provide a rough picture of the social, economic and environmental impacts that can be foreseen as a result of flooding within an area with potential significant flood risk. Analyses should be made for 2–3 different hydrological scenarios such as:

- » Floods with a low probability, or extreme events scenarios.
- » Floods with a medium probability (likely return period ≥ 100 years)
- » Floods with a high probability, where appropriate

The different situations in the European countries give that the tradition how to choose hydrological scenarios varies a lot. In the Netherlands, with a raising sea level as the most important risk, the worst possible scenario is today represented by a sea level with a return time of 4 000–10 000 years. The dykes towards the sea are constructed for such a scenario includes factors like a rising sea level due to climate change. Germany has chosen a recurrence time as 200 years as the extreme event for working with their greatest threat, the rivers. Norway looks at three different recurrence times, 10, 100 and 500 years not including an effect of climate change. In the Swedish pilots we have chosen two scenarios, a 100 years recurrence and a worst possible case including a factor for strong wind and a factor for climate change.

The flood risk maps should be able to point out vulnerable areas where more detailed investigations need to be done and where action may be needed. Since it's a rather large scale mapping that needs to be done, GIS instrument are ideal but complementary investigation of local business records and other types of registers is needed in order to obtain a reasonably accurate picture of effects of a flooding within an area. Presentation of the information should be primarily digital, using existing digital systems.

The Swedish SAWA-group has focused on making flood risk maps for the pilot areas Karlstad and Lidköping, situated at the shore of lake Vänern. The city of Karlstad is also affected a lot by the river Klarälven, that flows through the city centre. Some of the conclusions from the work will be presented further down in the text.

Population

All presented analyses of the impact on the population so far mainly look at property owners and public registers of inhabitants in different areas, in order to get a rough picture of how many people will need a temporary home during a flooding. The analysis are therefore not taking into account more indirect effects such as work places, schools, health care centres, important infrastructure etc which functions are crucial for society

Economic Activity

What constitutes economic activity is not clearly defined in the text of the directive. SAWA, Sweden interpreted this as meaning various different companies. By cross-referencing addresses and company records in the flood affected areas, the local authority in Lidköping has produced data on how many companies could be affected by a water level of 47.4m in the Vänern. The conclusion, in Lidköping's case, is that almost 550 companies are located in the flood-affected areas. This includes major industries to small service companies, in various sectors. For a town with a total population of 25, 000 inhabitants 550 companies represents a potentially important economic impact.

One can also consider studying land use in order to get idea of the consequences of a flood. To give a price tag on different types of land use also provides the flooding with a cost. This method is used in Hamburg and in the Netherlands. To estimate the price for different types of land is not a trivial thing to do in itself though especially on a large scale.

Environmentally hazardous activities

Updated registers of environmentally hazardous activities are held by both the local and regional authorities in Sweden. The registers are digital and coordinated hence easily to regard in any GIS analysis.

Other information which the Member State considers useful

Risk maps should contain any other information which the member state deems useful, such as an indication of the areas where floods with a high content of transported sediments and debris may occur and information about other significant sources of contamination.

Examples could be

- » Potentially contaminated sites
- » Sites of historic interest
- » Key community infrastructure such as socio-critical facilities and functions whose exclusion may result in a significantly larger number of people affected by flooding than just those who have their homes within the flood-affected area. Examples of important community activities that need to be identified are, Health care facilities (clinics, nursing homes, etc.), water utilities (sewage and water works, including related installations necessary for their operation), power stations and heating plants (that supply much of the urban area with district heating) and major transport routes and bridges.

Difficulties and limitations

- » Some political work remains such as defining what is a potential significant flood risk and what is an acceptable risk.
- » There are no guidelines yet for making flood hazard and risk maps according to the flood Directive
- » It's not clear how to regard climate change in the different calculations
- » The information that will form the basis of risk maps is scattered between the various authorities such as county councils, road management, rail management, affected municipalities and, not least, among private enterprises. In order to give an accurate picture of the impact on economic activity, it is important that different participants are involved in the work.
- » A limitation in Sweden in making large-scale flood surveys is the national elevation database. Using it gives such large errors that the mapping does not add any new knowledge and is therefore not useful, either in the planning context or in relief work. The work to develop a new database started in autumn 2009. By the year 2015 Sweden will have the equivalent prerequisites as the Netherlands, Germany and Norway.

On the Way to a Flood Risk Management Plan

E. Pasche, N. Manojlovic

Institute of River & Coastal Engineering, Hamburg University of Technology, Denickestrasse 22, 21075 Hamburg, Germany. (e-mail: pasche@tuhh.de; natasa.manojlovic@tuhh.de)

ABSTRACT

The Flood Directive EC 2007/60 specifies very clearly the structure and objectives of the flood risk management plan and the favourable mitigation measures to be taken for reducing the risk. However little information is given about the strategy to develop and implement this management plan on a local level. Obvious is the need for finding a good governance concept which is supporting the implementation process best and which will lead to acceptance and proper application of the new paradigm in flood risk management. A fundamental issue that is still to be resolved is how the necessary multi-stakeholder participation in the decision-making process can be carried out cost-effectively and in a timely manner so that the results are not only near optimal but also socially acceptable. What are efficient ways of public and stakeholder participation in the planning procedure, what is the appropriate method to quantify the efficiency and effectiveness of the mitigation measures and the necessary needs to adapt administrative and legal systems? The Flood Directive EC 2007/60 does not give any guidance in developing a good governance concept for the implementation of the flood risk management plan. It only requires the participation of the public (Article 10 (2)) in the development and implementation process. "Member States shall encourage active involvement of interested parties in the production, review and updating of the flood risk management plans referred to in Chapter IV."

Two different ways of public involvement are possible, a top-down and a bottom-up approach of decision making. In the first case the plan is developed by professionals. Public's opinion and input is only requested through public hearings and written objections at the end of the approval process. Article 10 (2) encourages seeking active involvement of stakeholders in the whole planning process. This public involvement stands for the bottom-up approach. Here all stakeholders, professionals and public are involved right from the start and together they develop the plan in a continuous collaborative process. Especially in urban environment, where many conflicting interests occur, this broader involvement of the public stakeholders is crucial. SAWA tries to contribute to this discussion of good governance in flood risk management by experimenting with different strategies in participatory flood mitigation planning. The partners will analyse and exchange their experience and intend finally to disseminate the outcomes in a guidance document.

Six Flood Risk Management Plans are going to be developed by the partners from Karlstadt/Sweden, Melhus/Norway, Hamburg/Germany and the waterboards of Noorderzijlvest and Hunze en Aa's. In these case studies the flood conditions vary considerably, ranging from pluvial/fluviat floods in a small urban catchment (City of Hamburg, Germany), to fluviat floods at canals in rural environments (Province of Groningen, Netherlands), lake floods affecting the urban environment (City of Karlstadt and Lidköping in Sweden) and fluviat floods with land slide (municipality of Melhus/Norway). The experience of extreme floods and their consequences varies considerably. While in the cities of Karlstadt and Lidköping the impact of the recent floods of the lake Vänern is still present in the public awareness, the population in Hamburg and in the Province of Groningen did not face a flood hazard in the last decades but is concerned about the consequences of climate change. Great differences between the case study areas exist in the national legislation and in institutional organization and responsibilities. The city of Hamburg and the water boards have more sovereignty in water management. Countries like Norway and Sweden are much more centralized, hampering the flexibility in the development of a FRMP.

Forced by national law the City of Hamburg has begun with the development of flood risk maps before the start of SAWA giving the partners in Hamburg a comfortable starting position for developing a FRMP. In Sweden and Norway the partner were at the beginning of SAWA in the situation that the government had not even decided about the institution which is responsible for implementing the EU Flood Directive. The Dutch partners had already set up flood risk management plans but in the context of national water laws. Their interest has been more in finding efficient ways to adapt these plans to the needs of the EU FD.

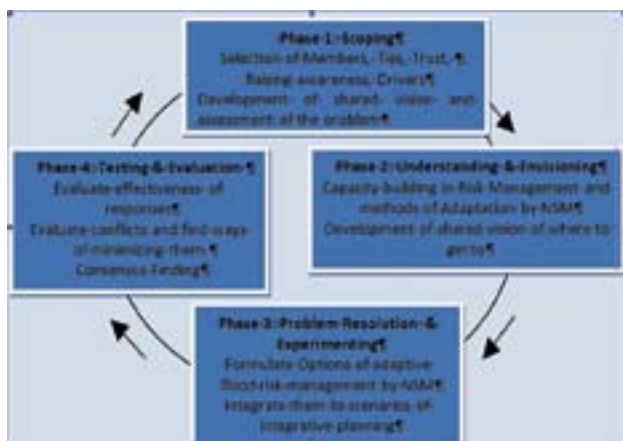

FIG. 1: LEARNING AND ACTION CYCLE IN FRMP DEVELOPED BY TUHH

As in the urban case study area of Hamburg many interests were conflicting the partners of Hamburg were looking for an early stakeholder involvement in the planning process. They established a Learning and Action Alliance (LAA) in which public and professional stakeholders develop together the FRMP of the urban river Wandse. The task of planning is regarded as a process which follows a 4-step-cycle of learning and planning (Fig. 1). Four workshops have been already organized in which a good level of awareness of the flood risk have been created and all stakeholders have understood the complex system of drivers, pressures and consequences (phase 1). Eight further workshops are planned for the remaining phases in the next months. A new Decision-Support-Tool (KALYPSO Planer-Client) will be introduced in the LAA enabling the stakeholders to define scenarios of drivers (urban development and climate change) and flood mitigation (non-structural measures) and to evaluate the impact of pressures and the efficiency of mitigation scenarios.

The partners in Sweden, Norway and the Netherlands build on their experience in participatory planning and the network of stakeholders built up during the implementation of the EU Water Framework Directive. They will intensify the discussion with the stakeholders through organizing a set of workshops in which ideas and solutions of flood mitigation and adaptation to climate change will be presented and through discussion and adaptation of the plan it is expected to find a consensus of all stakeholders.

It is the objective of this contribution to show the different solutions of governance the partners of SAWA have taken to develop and implement a FRMP along the rivers of their case study areas. The concept of Learning and Action Alliances (LAA) will be presented, the possibilities of stakeholder involvement in the planning process discussed and critically assessed on the experience collected so far by all SAWA-partners. At the end an outlook will be given about the activities and actions for the remaining duration of the project and about the way the different solutions and experiences produced by the partners will be integrated into a guidance document.

How to use existing Flood Risk Managements plans for the Flood directive.

Presentation on the SAWA midterm conference in Göteborg May 2010

by Jan den Besten from Waterschap Hunze en Aa's, in the Netherlands

The presentation is built up in 4 parts:

- » Historical perspective
- » Recent flood management plans
- » use of existing plans for Flood Directive
- » What is new due to the FD

Historical perspective

Why are people living in areas with a threat of flooding?

Why don't they build their villages on high dry spots?

It is a matter of weighting cost against benefits and the profits are often higher than the costs. That is why rich ancient societies arose along river valleys and sea coasts. Like along the rivers Nile and Euphrates.

But also closer to home we can find a pre-historical example. In the period 500 before Christ in the north of Germany and the Netherlands and in South West Denmark emigration started from the high dry but poor sandy soils to low flood plains with rich soils along the North Sea. Because those areas where flooded sometimes they made artificial live hills and built their houses on top of those hills.

Today still a great part of the big and wealthy cities are situated along rivers and coasts, like Hamburg, London, Antwerp and Rotterdam and the Ruhr area.

The attitude of the societies living in those flood prone areas was the make maximal use of the profits of there surrounding and to try to reduce the risks of the flooding by building flood protections like dikes, live hills etc. This resulted in plans that can be seen as types of Flood Risk Management Plans (FRMP) and in the establishment of the first Waterschappen (1289).

Some of the recent Dutch plans are interesting to look at. Like the "Plan Lely" (1918) and the first "Deltaplan" (1958).

In 1891 the safety problem was that the North Sea coast was well defended by the Sand dunes that are now up to 50 m high. But the sea could enter the land by the "Back door" through the lake IJsselmeer. So the proposal was to shorten the coast line. But the mayor incentive was the potential economic profits of the construction of large new polders with rich agricultural land.

It took 27 year and two disasters, a flood (1916, 20 victims and a lot of damage) and a famine (1918), before the plan was approved. The big "Afsluitdijk" took only 5 years to be built. But the other parts of the plan, mainly the construction of big new polders for agriculture, took more than 65 years. The cynical learning point of this plan is that it takes sometimes a disaster to get political support for a FRMP.

A more recent plan is the first Deltaplan. It was made in 1953 as a reaction on the disaster flood of 1953 that caused 1800 deadly victims in the South western part of the Netherlands. The approval took still 5 years and the realization period was nearly 40 years. The character of the measures was very technical. A lot of hard infrastructure was built to cut of sea arms in order to shorten the coastline in the South wet Delta. The learning point from this plan was that the cost of big new big innovative infrastructure is hard to plan (the costs of some of the dams doubled during the implementation period). Another learning point was the un expected ecological effects. The water quality in the closed sea arms that had no fresh water supply deteriorated severely and the new dams had a huge impact on the current and sand deposition on the sea side of the dams.

Recent flood management plans

A short round along the SAWA partners learned that several countries recently made plans or developed actions to reduce flood risks. Most big plans were made as a reaction on flood events.

Norway

Norway made plans after a large flood event in 1995. As a result a yearly 6 million Euro program have been started to build or repair flood defence infrastructure. Also 120 flood inundation maps have been made for catchment areas. The maps are used to control spatial planning. They help to prevent the development of new urban areas in flood prone zones.

Sweden.

Due to lack of big flood events Sweden has no recent national plans on flood control. But the national building act have recently been changed to prevent new settlements in vulnerable areas. Some local cities made flood risk management plans after local floods. Since 1990 the power industry systematically works on securing their large hydro power dams. Breakage of such dams is the mayor flood risk in Sweden. It would cause a national disaster by drowning downstream cities.

Germany

The Elbe floods in 2002 caused 21 deadly victims and a lot of economic damage. As a reaction a FRMP was made in 2003, called the 5 point Elbe Program. The 5 points include:

- » A shared program of the so called Länder (federal states) and the national government
- » Action plans on the international level
- » Promotion of cooperation concerning the EU
- » Evaluation of planned measures for the construction of waterways
- » Immediate measures

The shared program between federal state and national agencies had three main lines: "Give more room to the rivers," enhancement of de-central retention and controlled development of settlements and industrial areas

This 5-point-program was the base for the federal states to develop their own flood protection plans.

Netherlands

In 2009 a National waterplan was made on how to cope with sea level rise and climate change. This plan was developed parallel to the FD and covers nearly all aspects of the FD.

Main lines in this plan are:

- » 3 level security: Prevention (dikes etc.), control on spatial planning and disaster management
- » Use of natural processes: as supplementing sand in front of the north sea coast to stimulate the growing of the dunes;
- » Use of innovative ideas like dikes that are resistant against overtopping of waves and unbreakable multifunctional dikes.

On regional level all Dutch Water boards made in 2002 regional river basin visions. For the North East Netherlands the main lines in this vision were:

- » Creation of upstream water retention
- » Looking for multifunctional land use:
 - Combination of water measures with nature development.
 - Combination of water measures with river restoration (WFD).

Use of existing plans in the FRMP for the FD

Most of the different plans have in common the ambition to prevent the development of new urban area in flood prone areas. However the priorities in the plans differ a lot between the plans. In some areas the mayor flood risk comee from the river. In other areas breaking of hydro power dams or sea defences cause the main risk. So the plans will differ strongly on the main problems, the priorities and so also on the approach and required measures.

The general idea is in all countries to use existing ideas and experience from recent plans in the FRMPs for the FD. But often the discussion is still going on about how to do this in detail. In the Netherlands so many plans already exist for the main risk, the sea defences, that has been chosen for an approach of "growing FRMPs". The first generation FRMPs (to be made in 2010/2011) will just be a compilation of existing national and regional flood risk management plans. In a second phase it will be checked if these first generation plans are FD-proof. A first scan indicates that not much extra work has to be done to make the definitive FRMP.

What is new due to the FD

Due to the FD most countries expect an impulse on flood awareness and as a result better organisation of disaster management. Also experts expect improvement of local flood warning systems (N) and DSS (NL) due to the FD. For some countries thanks to the FD Climate Change and sea level rise will be new aspects in FRMPs (N, S). Germany expects that in their FRMP for the FD safe guarding zones of 1/100 year can be included. In these zones no further building or industries are allowed. The FD also might give an impulse to improve collection of basic data like better and more detailed elevation data (S).

Climate change projections and flood risk management

Deborah Lawrence, Norwegian Water Resources and Energy Directorate (NVE)

Phil Graham, Swedish Meteorological and Hydrological Institute (SMHI)

The management of flood risks in Europe is a crucial component of climate change adaptation and the EU Flood Directive requires member states to take account of climate change in flood risk assessment. This summary gives examples of methods available for generating climate change impact assessments for use in flood risk management, as applied in the countries represented in the SAWA project. There are considerable climatic and geographic differences between these countries, and the importance of particular climate change impacts on flood risk varies across the region. Common themes, however, include the role of sea level rise and increased storm surges in coastal flooding, of more frequent and intense extreme precipitation on pluvial and flash flooding, of increased precipitation on rapid stream flooding and longer duration riverine and lake flooding, and of changes in the seasonality of peak flows and associated flooding events.

The analysis of climate change impacts on flood risk is dependent on the availability of climate projections at temporal and spatial scales suitable for assessing factors flood generating processes at a local scale. Due to their coarse spatial resolution, direct use of output from Global Climate Models (GCMs) is generally unsuitable for such investigations, and the application of a series of additional models and analyses is required to produce meaningful impact assessments. For example, the analysis of likely future changes in the flood of a given return period requires the use of climate data derived from a Regional Climate Model (RCM), which are in turn further adjusted with statistical downscaling or bias correction methods before being used as input to a regional or local hydrological model. The estimation of changes in return periods, water depths and spatial patterns of inundation requires the further application of flood frequency analysis and hydraulic models. As the outcome can be quite sensitive to alternative models and assumptions available at each step in this modelling chain, the use of ensemble methods that sample a wide range of outcomes is being implemented in some cases.

The use of ensemble methodology has the potential to both satisfy the planners' and engineers' demand for 'one number please' (for example, the median of all outcomes), whilst retaining a representation of some of the uncertainty in a given projection. The construction of probability distribution functions from the sampled ensemble also allows the likelihood of a given change to be quantitatively estimated. An obvious disadvantage of this approach is that it can give the impression that all

uncertainty has been accounted for in the analysis, and that future flooding events will not exceed the estimates generated by the model ensemble. As an alternative, rather than attempting to provide precise estimates for future flooding conditions, output from hydrological simulations can be used more qualitatively, for example, to identify areas most likely to experience adverse impacts on flood risk under a future climate. General knowledge of expected likely changes has also been used to estimate 'climate' correction factors for application in flood management planning.

There is considerable variation within the North Sea region as to the projected impacts of climate change on flood generating processes, the availability of suitable data and analysis for assessing the implications of these impacts on flood risk, and the organisation and use of available resources and knowledge regarding climate change in flood risk management planning. The brief summaries for individual countries that follow are based on materials provided by contributing partners within the SAWA project and are not comprehensive. They do, however, provide examples of how knowledge of climate change impacts is under current and planned use in flood risk management planning.

Germany

There is no national agency responsible for providing climate change projections in Germany, although the Max-Planck Institute for Meteorology (MPI-M) often supply necessary data. Information is also available at <http://www.klima.de>. Flood protection is the responsibility of individual federal states, so methods used to account for climate change vary across Germany. Some federal states have developed 'climate factors' for the dimensioning of flood protection facilities, whilst others are undertaking detailed calculations of potential changes in water levels. In Hamburg, projections based on the MPI Echam4 GCM, dynamically downscaled with the REMO RCM have been used in conjunction with hydrological and hydraulic modelling to estimate changes in flood inundation.

Norway

Work on climate change impacts on flooding is being undertaken as a part a national strategy for climate change adaptation. General background material on projected regional changes in precipitation and flooding has been published in a national report on 'Klima i Norge 2100' (<http://nou-klimatilpassing.no>). Projected changes in sea level and in storm surges by 2050 and 2100 have also been estimated for all coastal municipalities, and further work is being undertaken at the county and municipal level. The Norwegian Water Resources and Energy Directorate (NVE) has responsibility for climate change adaptation with respect to stream and river flooding. For this work, ensemble modelling of likely changes in the 200-year flood based on a range of climate models, downscaling methods and hydrological models, is being undertaken for the 2021–2050 and 2071–2100 future periods. The regional climate models applied were obtained from the EU FP6 ENSEMBLES project, with statistical downscaling to a 1 x 1 km grid by the Norwegian Meteorological Institute. The hydrological scenarios are used to identify regions and catchment types most likely to experience increased flooding in the future. Flood zone maps within these regions will be prioritised for more detailed analyses of potential changes in flood inundation.

Sweden

The Swedish Meteorological and Hydrological Institute (SMHI) is the national provider of both downscaled climate projections and operational flood forecasting. They have done extensive work to couple projections of future climate with hydrological modelling to attain estimates of how climate change can affect future flooding conditions. Using locally developed bias correction methods, SMHI also performs hydrological ensemble simulations from RCM projections, currently including 16 projections from both the EU FP6 ENSEMBLES Project and projections produced at SMHI. All cover the period 1961–2050 and most continue to 2100. Future flood risk for the large Lake Vänern basin is in focus for the SAWA Project, and the change in risk for high river inflows and associated high lake water levels is being analysed. Detailed analyses of changes in short-term intense precipitation are also included, which contributes to the assessment of urban flood risk. Nationally, an ensemble analysis of expected future change in 100-year flows and the probable maximum flood are under investigation. The additional effects of sea level rise for coastal basins are also being investigated on an ad hoc basis.

The Netherlands

The Dutch Royal Meteorological Institute (KNMI) provides climate change projections for further use in climate change adaptation (<http://www.knmi.nl/climatescenarios/>). They have developed regional projections for changes in, for example, seasonal average rainfall, the number of rainy days and the 10-day rainfall volume with a return period of 10 years, together with projected changes in sea level. The projections were developed in 2006, and are given as four possible scenarios, representing a global temperature change of +1°C vs. +2°C by 2050, with and without possible changes in atmospheric circulation patterns producing wetter winter and drier summers. Work on updating the scenarios is underway and will be published in 2013. The estimation of likely changes in hydrological conditions and flooding is the responsibility of the province or water authority. The authority Waterschap Hunze en Aa's, for example, are planning to use available projections, together with hydrological and hydraulic models, to consider changes in flood risk.

United Kingdom

Recent standard practise for accounting for climate change effects in flood management in the UK has been to add a fixed percentage increase to a particular quantity. For example, Catchment Flood Management Plans in England consider the sensitivity of flood risk to a 20% increase in the 100-year flood, and SUDS systems in Scotland have been designed based on the assumption of a 10% increase in flows. The justification for such correction figures came from the 2002 UKCIP (UK Climate Impacts) report, which provided projections for changes in climatic variables reported across a 50 km grid. The UKCP09 report is, however, now available (<http://ukclimateprojections.defra.gov.uk/>) and provides regional probabilistic projections based on an ensemble of climate models, which take account of uncertainty from intermodel differences and natural variability. In addition to the regional projections, a statistical downscaling tool incorporating a weather generator is provided as a tool with this report, so that local hydrological conditions can be simulated. Data and methods from this new report are being taken into use in climate change adaptation.

**SAWA's approaches to adaptive measures
and their application & selection**

Wiki Catalogue of Measures Concept

Tobias Ernst (tobias.ernst@hcu-hamburg.de), Prof. Dr. Wolfgang Dickhaut (wolfgang.dickhaut@hcu-hamburg.de)
– HafenCity Universität Hamburg

Background:

The objectives of SAWA Work Package 2 are to:

1. Compile a transnational inventory of currently available strategies and experiences on implemented local scale non-structural and structural measures based on case studies.
2. Develop hybrid (Flood Risk Mitigation/Water Framework Directive) adaptive non-structural measures to be implemented into FRMPs. Assessed optimised and prioritized using a holistic cost benefit analysis (CBA).
3. Design a case-based-reasoning decision support (DSS) database holding new adaptive and state of the art measures for all SAWA-partners, accessible via Internet.

HCU proposed the working scheme shown in figure 1 to meet these objectives.

State of Play:

SAWA partners agreed on starting to build the inventory with the flood risk mitigation measures put forward by Pasche, Ashley, Lawson, Schertzer (2008): „Risk Assessment and Risk Management in Small Urban Catchments“ as a basis for further development. Each measure shall be described as well in general and using case studies as practical examples.

For the interactive collection of information needed to describe and assess the measures a wiki-platform was finally chosen, prepared and opened for SAWA-partners to contribute (see screenshots in figure 2–4). One main motivation to choose a wiki-system was that it could allow for opening the SAWA Wiki Catalogue of Measures (WCoM) after the project thus having the chance to be continued by interested visitors. At the moment the WCoM is hosted by the Heriot Watt University of Edinburgh and not open to public.

The template determining the information to be gathered was developed by HCU in cooperation with SAWA Work Package 2 Partners and implemented in the wiki system.

The collection of information needed to build the inventory of measures has begun. As the wiki-system will not allow analysis of data, Leuphana University and HCU assessed the possibility of building a filemaker-database that could be opened to public like a wiki system and could allow for implementation of DSS structure itself. Though feasible it showed not be possible with the given resources. WP Lead and Project Management will have to decide on how to proceed.

Working scheme proposal to reach SAWA WP2 objectives

↓ identify measures & build inventory (literature review)

inventory of flood risk mitigation measures

(structural & non-structural measures, WFD measures with potential to reduce flooding risk, search for hybrid adaptive measures)

↓ describe measures (literature review, case studies)

database of flood risk mitigation measures

(containing information on costs, mode of action, required space, conflicts & synergies, adaptivity, pros and cons...)

↓ assess measures (building a target system and expert judgement or delphi)

CBA information on flood risk mitigation measures

(to be put in the database of flood risk measures)

↓ assess measures applicability regarding physical and cultural preconditions, develop query logic, build user interface

DSS to facilitate choice of feasible measure combinations in FRM-planning

(details see figure on the right)

Figure 1: Proposed working scheme to meet WP2 objectives, developed by HCU

Measures featured in the WCoM

We will start building the WCoM with the following measures, which are grouped following classification approach derived from Pasche, Ashley, Lawson, Schertzer (2008): "Risk Assessment and Risk Management in Small Urban Catchments" (pdf, 9MB) which has been amended:

Flood Resilience Measures

Capacity Building

- Flood Maps (might be grouped with flood risk maps)
- Flood Risk Maps
- Public Relations
- Capacity Building

Land Use Control

- Building Codes / Regulations
- Zoning Ordinances / Zoning Maps

Adapted Land Use

- Afforestation (might be grouped with Conversion to extensive Grassland and Land Set-Aside in 'Change of Land-Use')
- Conversion to extensive grassland
- Land Set-aside
- Conserving Cultivation (might be grouped with Depth Loosening and Partition of Fields with Green Corridors to 'Optimization of Agricultural Practices')
- Depth Loosening
- Partition of Fields with Green Corridors / Strips

Contingency Measures

- Protection, Evacuation and Rescue Plans
- Forecasting and Warning Services
- Control Emergency Operations
- Mobile Flood Defence Constructions
- Disaster Response Plans

Figure 2: Screenshot of the WCoM page Measures featured in the WCoM

Rain Gardens [back to the List of Measures featured in the WCoM](#)

A rain garden is a planted depression that allows rainwater runoff from impervious urban areas like roofs, driveways, walkways, and compacted lawn areas the opportunity to be absorbed. This reduces rain runoff by allowing stormwater to soak into the ground (from Wikipedia).

On the surface, a rain garden looks like an attractive garden. It may support habitat for birds and butterflies, it may be a formal landscape amenity or it may be incorporated into a larger garden as a border or as an entry feature. What makes it a rain garden is in how it gets its water and what happens to that water once it arrives in the garden.

There are two basic types of rain gardens - under-drained and self-contained. Both types of rain gardens are used to improve stormwater quality, reduce runoff volumes and generally facilitate infiltration of cleaned water. Which type of garden is selected to be built is a balance of volumes of water to be treated, existing soil conditions, available space, and budget for the project (from Rain Garden Design Template).

Rain gardens can be used wherever human activity has hindered infiltration.

Measure Description:

- Pictures
- Mitigation Strategy
- Time to take Effect
- Pros & Cons
- Performance Drawbacks
- Literature
- Related Legislation & Technical Standards
- Related Projects & Weblinks
- Cost Data Summary
- Financing Instruments
- Case Studies

Editing help: Please give a short description of the measure containing the most important characteristics. Please add the date you begin editing this measure.

Figure 3: Screenshot of the WCoM page Rain Gardens – measure description

Pictures [Top of Page](#)



A small rain garden is possible to retrofit in areas with established houses.



Editing help: In the Editing Mode you can add pictures using the wiki media database. Here is help if you have difficulties (How to add pictures). Please give a short description of what the picture is showing (if possible add: why this is interesting, information from where and in which direction the picture was taken). Please make sure to complement the following information in the bracket: Country and date the picture was taken, the decimal geodetic coordinates (How to determine coordinates), who took and added the picture.

Figure 4: Screenshot of the WCoM page Rain Gardens – pictures

Meaningful Stakeholder Engagement

Unwin D. & Arthur S.

Sustainable Water Management Research Group, School of the Built Environment, Heriot Watt University, Edinburgh, EH14 4AS, Scotland, U.K. Work-Package 2

Research Summary:

The research presented focuses on developing a sound methodology in applying multi-dimensional and majority rule Game Theory techniques to analyse and inform the selection processes used when deploying adaptive Flood Risk Management Plan (FRMP) measures in a real world case study located at Dumfries, Scotland.

The research details how cooperative, Pareto-optimised, conflict resolution techniques can be used to support how key FRMP decisions are made. The research reports on the benefits that may be gained through assessing how different stakeholder views are to be accommodated, through an approach to structure, analyze, and understand strategic scenarios.

The research methodology presented enhances the development of collaborative outlooks within the case study area to increase the overall project benefits and evaluation through enhanced stakeholder communication, and improved coordination.

Case Study Area:

Figure 1 shows the case study area in Dumfries, Scotland. The case study FRMP consists of 2 inter-connected aspects, namely:

- » Up-stream aspect
 - Use of 1500 acres of mixed agricultural land as a Flood Retention Volume (FRV) to be used in more extreme events, as shown by the hatched area of Figure 1.
- » Down-stream (Urban) aspect
 - Construction of a part permanent (1.3 m), part demountable (0.8 m) flood protection barrier located in the area highlighted by the ellipse of Figure 1.

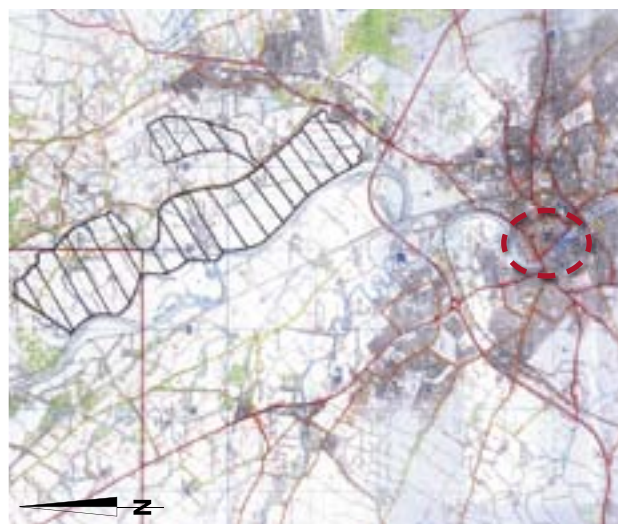

Figure 1. Case Study Area, Dumfries, Scotland

Methodology:

The research presented here follows a process/timeline of:

- » Primary phase: Stakeholder contact and Mapping
 - Used to assess stakeholders in terms of Interest, Attitude and Influence on a FRMP
 - The approach has provided an insight into the potential for future negotiation
 - Provides an insight into the balance/distribution of stakeholder characteristics
- » Secondary Phase: Stakeholder Engagement
 - Informal one-on-one discussions of core values
 - Process detached from any agenda
- » Tertiary Phase: Data Analysis
 - Distribution of core value responses
 - Conflict analysis
 - Identification of key issues of a FRMP and how these 'map' onto stakeholder core values

Results:

The results showed that the key 'issue' in terms of degree of conflict, as is shown in Figure 2, was the duration effects of a flood incident and that how this issue was viewed depended upon the location of the people directly affected, for example:

Up-stream effects:

- » Stakeholders felt that extended single usage or repeated frequent usage of the up-stream agricultural land as a flood retention volume would lead to a change in both habitat and current management practices that would result in current farming practices becoming (potentially) un-viable.

Down-stream effects:

- » It was felt that a general reduction in the likelihood and/or duration of flood incidents and the effects of any subsequent access (to the town) closures due to health and safety considerations immediately prior to, during and after the flood event (during clean-up) would result in certain local businesses that are most directly affected by flood incidents to remaining viable.

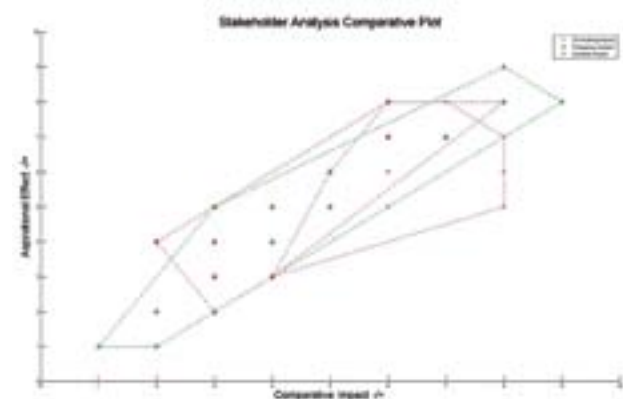

Figure 2 : Case Study Key Issue 'Conflict' Comparisons

FD – WFD Synergetic Measures

Tobias Ernst (tobias.ernst@hcu-hamburg.de), Prof. Dr. Wolfgang Dickhaut (wolfgang.dickhaut@hcu-hamburg.de) – HafenCity Universität Hamburg; Prof. Dr. Mariele Evers (evers@leuphana.de) – Leuphana Universität Lüneburg

Very often measures for flood risk management and increasing of water body quality are going hand in hand. Therefore one activity of SAWA project is to identify potential synergies between measures due to the implementation of the Floods directive and Water Framework Directive.

Two approaches shall be presented here: one is the Integrated River Basin Management Plan for the river Ilmenau (this project is conducted by Leuphana University of Lüneburg/Germany); the other is the case study on river Wandse catchment (project conducted by HafenCity University).

For the catchment of the river Ilmenau following approach has been chosen. A catalogue of potential measures is worked out which includes types of measures from different action areas such as agriculture, urban drainage, information management or capacity building; their implication between each others are illustrated and specific instruments for measure implementation are described. Furthermore a spatial analysis to identify areas of high flood risk and appropriate areas for measure implementation for the whole catchment is conducted. The results are presented on a web-based platform. Against this background a prioritisation of measures is planned together with regional stakeholders. In the following the Wandse project is described more detailed.

In the regional project “Implementation of a Flood Risk Management Plan (FRMP) for the Catchment of the river Wandse” in Hamburg, Germany, HafenCity University (HCU) is contributing to the planning process of the flood risk management plan with regard to integrate aspects of the Water Framework Directive (WFD) (Articles 9 & 10 of the Directive on the assessment and management of flood risks (FD)).

Based on an assessment of the deficits and measures given in the first River Basin Management Plan and associated documents HCU strives to identify measures that as well help to reach WFD and FD goals and tries to quantify their potentials.

The River Wandse and its Catchment

The river Wandse is located in the federal states Hamburg and Schleswig-Holstein, Germany. It is one tributary of the River Alster, that runs into the River Elbe on Hamburg territory. The Wandse has a total length of 21,5 km with a catchment area of 88 km². The source is located in Schleswig-Holstein with the upper part of river and catchment (approx. 4,2 Km and 20 km²) having predomi-

nantly rural character. The lower part on Hamburg territory (approx. 17,3 km and 68 km²) is of urban character with a high percentage of sealed surfaces that drain to the Wandse or their tributaries (approximately 63,5 km length). HCU research focuses on the Hamburg territory.

WFD Deficits and envisaged Development in RBMP

Due to technical river development in the 50es to 60es large sections of the Wandse suffer from structural depletion causing a deterioration of aquatic biocenosis’ (as well fish, makrozoobenthos and plants). Structures and their backwater stretches cut the Wandse in several habitats and cause the absence of migrating fish species. The water bodies have been classified as heavily modified.

The sealed surfaces in the catchment drain mostly unrestricted to the watercourses, thus causing hydraulic stress to the aquatic biocenosis’ aggravated through the combination with the structural deficits mentioned above. The rainwater canalization transports as well sediments, nutrients and pollutants from diffuse sources in the watercourses. Spillovers from a combined sewerage system can affect the lower reaches of the river even though this impairment could be reduced considerably in the recent decades. Several inlets of cooling water have degrading effect during periods of dry weather and reduced base flow, especially in the summer. Both ecological potential as chemical status’ (quality standards missed for: TOC, NO₃, N_{total}, PO₄, P_{total}, O₂, Zn, Cu, PAH, Tributiltin, Parathion-methyl) of the water bodies are classified as not good, necessitating measures to reach WFD goals.

The first RBMP aims to reach good chemical status and good ecological potential until 2015. According to the RBM measures to work towards good status (potential) in the first implementation period will be:

- » melioration of habitat structure at the river bed and banks
- » reactivating the floodplain where possible
- » construction of sand traps and addition of gravel substrate to the river bed
- » reconstruction / optimization of constructions hindering aquatic animal passage (esp. fishes)
- » concept for meliorating watercourse maintenance and training of personal in charge
- » concept for stormwater disposal points

FD – WFD Synergetic Measures and Potential Analysis

Against this background a screening of available flood risk mitigation (frm) measures shows that the measures listed in table 1 can be supposed as synergetic and were chosen by HCU for further potential analysis, because

effect and effectiveness, timeframe for realization, strategies for implementation and acceptance have thitherto not been investigated and discussed in detail for the Wandse catchment.

Table 1:

Synergetic Measures chosen for further potential analysis

measure	postive effects flood risk mitigation	positive effects WFD goals
decentralised storm water management, in particular run-off from traffic areas	building decentralised retention volume everywhere in the catchment, thus reducing peak-run-offs of all cyclonic rainfall events and of most convective rainfall events	reduction of sediment, nutrient, pollutant load; reduction of hydraulic stress; increase of base flow in periods of dry weather
activating retention potentials of the watercourse network by enlarging transverse profiles and roughness of the watercourses	building semi-decentralised retention volume in the watercourses, thus flattening the discharge wave and reducing run-off speed	reduction of hydraulic stress; melioration of habitat structure of river bed and banks
modification in the management of ponded sections of the watercourses	building centralised retention volume that can be operated targeted at the retention of extreme and rare run-off-peaks	restoration of aquatic animal passage; reduction of ponded stretches strengthen the typical biocenosis' of flowing waters

First part of the potential analysis is a rough quantification of retention volume that likely can be realized in the catchment using GIS resources and archive data available. A comparison to retention volume in the existing watercourse network and retention basins should allow for estimation if the measures can reach appreciable effects on run-off characteristics. Acceptance, costs, financing possibilities and timeframe for realization shall be investigated and estimated against the background of the existing planning strategies of urban development and water management in the Wandse catchment. Using the model STORM (Ingenieurgesellschaft Sieker) HCU will investigate how these measures change the run-off processes of different precipitation events (common – rare/short duration, convective – long duration, cyclonal) in small project areas.

These results shall be prepared for discussion and appraisal in the Learning and Action Alliance Wandse, a cooperative planning panel (see regional project WP1). If the measures are judged generally appropriate for flood risk mitigation, melioration of ecological and chemical status and not opposing existing planning strategies of urban development, their effect on the run-off processes in the Wandse watercourse network shall be modelled by the experts of TUHH using KALYPSO-software to see what effects can be reached if they are implemented in different intensities and timeframes in the whole Wandse catchment.

Managing Urban Creep

Grant Wright, Scott Arthur, Nicolas Bastien, Graeme Bowles & Darren Unwin

Sustainable Water Management Research Group, Heriot-Watt University, Edinburgh EH14 4AS, Scotland, UK

Background

The spate of high profile flooding incidents in recent years, both in the UK and further afield has highlighted the potential damages associated with urban flooding. There is now a growing realisation amongst all stakeholders that reliance on large scale structural defence measures in isolation is no longer a financially sound or sustainable future strategy to mitigate against the effects of flooding. Hence there is a move towards the use of local level "source control" measures, whereby surface runoff is dealt with at its source rather than being passed downstream, where the cumulative runoff from a large number of relatively small impermeable areas can significantly increase flood risk. This shift in emphasis is highlighted by the increasing use of sustainable urban drainage systems (SuDS). In addition to the impact on water quantity, there is also an increasing understanding of the beneficial effect of source control on water quality. As a result of the shift in emphasis outlined above, Heriot-Watt University, together with the Building Standards Division of The Directorate of the Built Environment (BSD) with the Scottish Government, undertook research project to investigate the extent and cost of designing and constructing small areas of hardstanding (driveways, small parking areas, etc.) around new and existing, domestic and non-domestic buildings.

Objectives

The primary aim of this research project is to further develop the evidence base necessary to support any proposed future changes to the building regulations relating to surface water runoff from small areas of hardstanding around buildings. In order to achieve the project aim, the following objectives must be met:

1. Quantify the extent of hardstanding retrofitting and determine whether measures to discourage such practice are justified.
2. Determine existing practice for the provision of traditional hardstanding (impermeable) and non-traditional hardstanding (porous/permeable) with particular reference to the whole life financial and other costs.
3. Identify any significant issues related to scale (5 m² to 200 m²) and building type/usage.

Methodology

The project is focussed on surface water runoff from areas of hardstanding around buildings in urban areas. Key to the philosophy which underpins the project methodology is the recognition that the process must be both independent and transparent. Within this context, stakeholder engagement is embedded throughout the project methodology. The project methodology comprised of 5 work elements, thus:

1. Review of current practice
2. Stakeholder consultation
3. Impermeable creep survey
4. Case study development
5. Reporting and consensus

Current practice

There are clear benefits associated with the use of permeable hardstanding solutions, both in terms of a reduction in runoff volumes and an improvement in water quality. An appropriately located permeable development, which has been well constructed and is adequately maintained, should have a design life comparable to an equivalent impermeable development. Furthermore, the maintenance of such areas should be no more onerous than equivalent impermeable areas.

Stakeholder consultation

The key messages to emerge from the consultation phase (including the stakeholder workshop) were:

1. There is universal appreciation of the potential impact that the cumulative effect of small areas of impermeable hardstanding can have on flood risk within urban areas.
2. There is universal appreciation of the need to better control the development of hardstanding, in order to reduce the total area of new impermeable surfaces.
3. The majority of stakeholders feel that other forms of urban creep (e.g. garages, extensions, etc) should also be subject to stricter standards to encourage the use of SuDS techniques.

Impermeable creep survey

The key messages to emerge from the impermeable creep surveys were:

1. Approximately three quarters of properties in the study catchments have some form of hardstanding (e.g. a driveway). The area of hardstanding is generally higher where the number of cars per households is higher, and may thus also be linked to socio-economic factors.
2. Nearly two thirds of the properties in the study catchments have increased the area of hardstanding within their building curtilage since purchasing their property.
3. The public would generally support a change in legislation to mitigate detrimental environmental impacts.

Case studies

The key conclusions drawn from the case studies were:

1. The stakeholder perception that impermeable hardstanding solutions are less costly than permeable alternatives are borne out by case study data, which suggests that initial construction costs of impermeable options are, on average, two thirds of those associated with equivalent permeable developments. However, these figures are based only on the construction costs of the hardstanding, and they hence neglect the additional costs required to drain and/or treat runoff from impermeable developments; when accounted for, these may well make impermeable solutions more costly to society as a whole than equivalent permeable options.
2. There do not seem to be any discernible differences between permeable/impermeable cost differentials except at the very smallest scale, where this differential is low relative to industry averages.
3. The expected design life and maintenance requirements of permeable and impermeable hardstanding do not differ significantly.

Conclusions

Based on the overall project findings, the following conclusions have been reached:

1. The installation of impermeable hardstanding is sufficiently widespread to justify measures to discourage such development.
2. Permeable hardstanding solutions offer multiple benefits to the urban drainage cycle and should be promoted, through legislation, education and incentivisation.
3. Traditional piped systems still have a role in sustainable development, particularly where concerns remain over future performance of permeable alternatives.
4. Improved guidance on the design, specification and installation of permeable hardstanding is required; such guidance should be drawn up and disseminated by a working group incorporating materials manufacturers and SEPA.
5. Improved public information is required to encourage the use of more sustainable, permeable hardstanding approaches; such information should be drawn up and disseminated via LA planning control. There may also be a role to play for some form of incentivisation scheme.
6. There is widespread support for a lowering of the maximum area of impermeable hardstanding that does not need to comply with relevant building standards. Additional resources may be required to adequately enforce the strengthening of existing legislation.

Further details on the project are available online:

Wright, G., Arthur, S., Bastien, N.R., Bowles, G. & Unwin, D., (2010), Extent and Cost of Designing and Constructing Small Areas of Hardstanding Around New and Existing, Domestic and Non-Domestic Buildings, Building Standards Division of The Directorate of the Built Environment, The Scottish Government. <http://tinyurl.com/Wrightetal>

Every calamity asks for decisions

A Decision Support System (DSS) is defined as;

“a class of information systems (including but not limited to computerised systems) that support business and organisational decision-making activities. A properly designed DSS is an interactive software-based system intended to help decision makers compile useful information from a combination of raw data, documents, personal knowledge, or business models to identify and solve problems and make decisions.”

The Dutch SAWA partners use DSS's mainly for their surface water management. For example to predict high water levels in their canal systems or to automatically control pumping stations and other water management structures.



Figuur 1 BOS Delfland. Used for everyday automatic control of main pumping stations

These systems can do this because all information needed to make the decisions involved, such as weather forecasts, tidal forecasts, expert knowledge, the possible range of outcomes and real time telemetry is con-

tained within and fed to the system. This information is structured in such a way that a predefined question can be 'answered' by the system. It can do so in a highly consistent manner and (near) real time.

Designing and implementing a DSS can be quite a task. However, the design depends entirely on the questions that need to be answered and the local hydrological situation.

SAWA focuses on a dilemma, flood prevention or mitigation of its effects. In either case, decisions need to be made and therefore a DSS can be used.

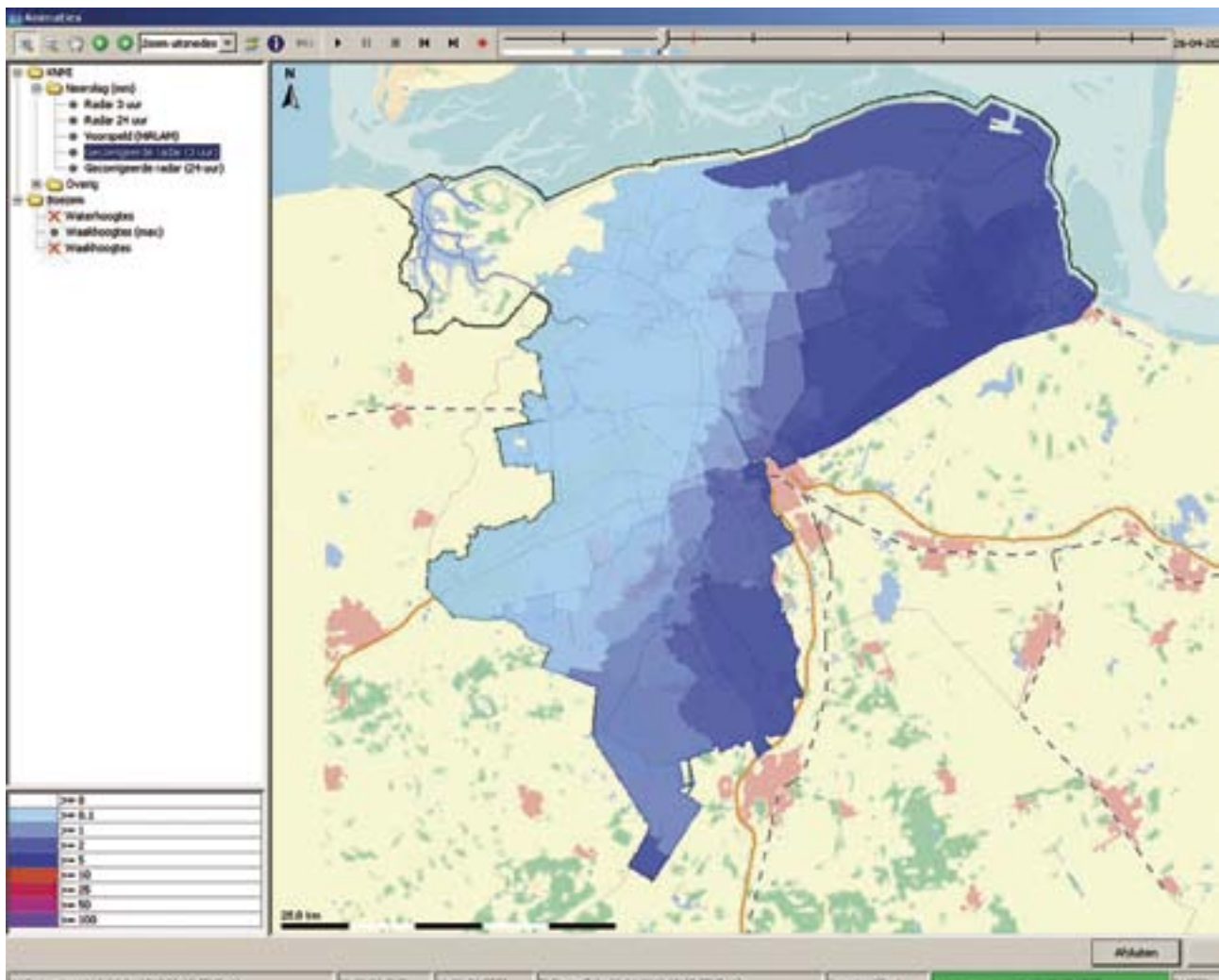

Figuur 2 BOS Noorderzijvest. Used to predict waterlevels in their main water system

The quality of crisis management depends on the information available to base decisions on. A well designed and finetuned DSS can offer a rapid and defendable re-

sponse under such conditions, for the decision is based on a large amount of pre-organised collective knowledge, experience and (realtime) information.

Sustainable Flood Retention Basins (SFRB) as Adaptive Measures

Qinli Yang¹, Junming Shao², William R. McMinn¹ and Miklas Scholz^{1,*}

¹Institute for Infrastructure and Environment, School of Engineering, The University of Edinburgh, William Rankine Building, Mayfield Road, The King's Buildings, Edinburgh EH9 3JL, Scotland, United Kingdom.

*Corresponding author; phone: 0044-131 6506780; fax: 0044-131 6506554. e-mail: m.scholz@ed.ac.uk

²Institute of Computer Science, Database and Information Systems, Ludwig-Maximilians University of Munich, Oettingenstraße 67, 80538 Munich, Germany.

Introduction and Background

Climate change is likely to increase the severity and frequency of flood events, thus increasing the associated hazard. This may threaten some existing flood defences, which were designed and built prior to climate change being identified as an issue; therefore, they may require modification to ensure their sustainability.

The European Union recognises that member states may face significant challenges in implementing the Flood Directive and has responded with programs such as the Strategic Alliance for Water Management Actions, which aims to provide tools and guidance to aid the member states in implementation. Flooding is a complex spatial planning issue and therefore requires a range of tools and approaches to solve the problem. Solutions are likely to require sustainable (urban) drainage system solutions applied on a small scale combined with SFRB used on a large scale (McMinn et al., in press; Robinson et al., in press).

SFRB Guidance Manual

The presentation provides guidance on 40 variables used to rapidly assess water bodies including SFRB in terms of their flood and diffuse pollution control purpose and potential. The variables described should be the basis for the characterisation of SFRB, which are adaptive structural measures well integrated within the landscape promoting best management practice as part of a sustainable flood risk management strategy (Robinson et al., in press). The variables Engineered, Outlet Arrangement, Aquatic Animal Passage, Land Animal Passage, Basin and Channel Connectivity, Seasonal Influence, Relative Total Pollution and Flotsam Cover are novel. The list includes also sum parameters such as Relative Total Pollution, which addresses as part of a simplified methodology several complex environmental processes.

SFRB Classification

In countries such as Scotland, there are a relatively high number of drinking water reservoirs (operated by Scottish Water), which fall within this defined category and could contribute to flood management control. Reducing the rate of runoff from the upper reaches of a catchment will reduce the volume and peak flows of flood events downstream, thus allowing flood defences to be reduced in size, decreasing the corresponding capital costs.

A database of retention basins with flood control potential has recently been developed for Scotland. The research shows that the majority of small and former drinking water reservoirs are kept full and their spillways are continuously in operation. Utilising some of the available capacity to contribute to flood control could reduce the costs of complying with the Flood Directive. Furthermore, the application of a previously developed classification model for Baden in Germany for the Scottish data set showed a lower diversity for basins in Scotland due to less developed infrastructure. The principle value of this approach is a clear and unambiguous categorisation, based on standard variables, which can help to promote communication and understanding between stakeholders (McMinn et al., in press).

Self-organizing Map Model

The Scottish database comprising about 350 water bodies was classified into six types of SFRB and non-SFRB using a classification method previously applied to a database of approximately 170 SFRB in Baden, Germany. However, this approach is time-consuming.

Therefore, a self organizing map model was applied to the database to allow visualization of the relationships between variables, to determine if individual variables could be predicted, and finally to classify the database by SFRB type, and compare the results to those of the current classification method.

The self organizing map model performed well in predicting certain variables cost-effectively. The results indicate that the model was an appropriate approach to characterize and classify various water bodies including SFRB. The prediction of the SFRB types based on 20 key variables outperformed the prediction based on all 40 variables, suggesting that 20 variables are optimal for classifying retention structures according to their sustainability and potential to contribute to sustainable flood management.

Spatial Data Analysis Applying Geostatistics

This presentation indicates for the first time how geostatistics can help water engineers with the analysis of spatial data. A spatial data analysis has shown that ordinary kriging can be successfully applied to estimate numerical values for all key flood control variables everywhere in the study area. However, the mean prediction errors were relatively high for the ordinary kriged variables associated with flood water volume.

Moreover, the probability that certain threshold values relevant for flood control managers are exceeded can also be calculated by using disjunctive kriging. The principle value of this analysis is a probabilistic spatial assessment of the flood control potential predominantly based on the variable Engineered, and the new variables Managed Mean Flooding Depth and Managed Maximum Flood Water Volume (Fig. 1).

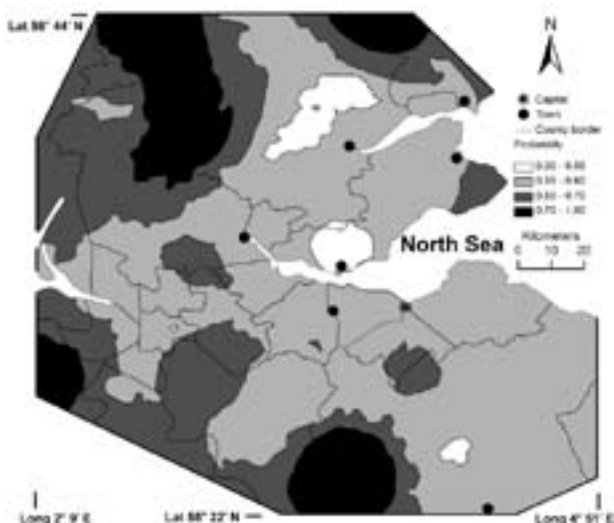

Figure 1. Map example of the application of disjunctive kriging for the novel variable Managed Maximum Flood Water Volume (m^3 , exceeding $35 \times 10^4 m$).

References

McMinn W. R., Yang Q. and Scholz M., Classification and Assessment of Water Bodies as Adaptive Structural Measures for Flood Risk Management Planning, Journal of Environmental Management (in press).

Robinson M., Scholz M., Bastien N. and Carfrae J., Classification of Different Sustainable Flood Retention Basin (SFRB) Types, Journal of Environmental Sciences (in press).

**SAWA's innovative ways in capacity
building & education**

Sustainability Education Centres – general information and Dutch examples

The SAWA project's approach is a vertical societal integration between all levels and parties involved. Sustainability Education Centres (SEC) set in strategic locations within the partner countries, will serve as hubs in this network for education and capacity building. SECs are aimed to be places of exchange, cooperation and social learning processes.

They will provide educational activities, tools and information on sustainable flood risk management for the public, schools and universities. Following SEC's are planned to be established within SAWA.

Sustainability Education Centres (SEC) planned in SAWA project

Institution	University of Karlstad	Waterboard of Delfland	Agency for roads, bridges and waters	Leuphana University of Lüneburg
Country	Sweden	The Netherlands	Germany	Germany
Name / Type	Centre for Climate and Safety (CCS)	<ul style="list-style-type: none"> – Mobile exhibit on waterquantity management – Keringhuis 	Dike protection centre (DPC)	Virtual Centre for integrated Water and Flood Management (vIWa)
Target groups	<ul style="list-style-type: none"> – Professionals – Students – Scientific society 	<ul style="list-style-type: none"> – Pupils – General public 	<ul style="list-style-type: none"> – Pupils – General public 	<ul style="list-style-type: none"> – Professionals – Students

Dutch SEC's for SAWA

The Dutch are internationally known for their battle against the water. Holland is famous for its mills, for winning land from the water, the delta works that protect our country from the sea and for keeping the lower parts –polders- of our country dry. The oldest governmental institutes of the Netherlands are the water boards.

The Dutch water boards are responsible for managing both water quality and quantity and for cleaning wastewater. There used to be thousands of them. Nowadays through merges there 25 are left. And, they are doing a good job. They have been doing such a good job, that most Dutch people have no idea what they are for. They have been doing such a good job that every time there's elections in Holland, politicians want to liquidate the water boards to accomplish cut backs.

The water boards raise their own taxes, they know what needs to be done to protect their part of the land against the water and to keep the water clean. Should water management become a task of the national government, then for money it will have to compete with healthcare, education, defense and so on. Most countries in the world facing water problems are envious of the Dutch system, none the less, most Dutch people would not mind giving up the water boards.

So, the water boards are facing an educational challenge. Delfland has picked up this challenge since the end of 2006. Delfland is a region in the south west of Holland with 1,4 million inhabitants, 40.000 institutes and businesses, and a large green house area. Due to the intense expansion of activities the increasing amount of houses, buildings and roads has forced Delfland to constantly adapt and improve the drainage system. Especially the green house area has presented us with challenges. This is the area where we have had some floods in the recent past (1998 and 2004). It is here where most people do not know what a water board is for...

Delfland is confronted with the effects of climate change. The rains are far more intense than we have ever experienced before and on the other hand we are facing longer periods of drought.

We have enhanced the capacity of our pumping stations, we have widened canals, and realized retention basins. We are also finalizing a large program on the improving of our regional barriers. The DSS system Delfland is working on is the crown on these investments. Also we are facing the effects of sea level rising. To keep our area safe we are reinforcing both the Delfland coast and the Scheveningen Coast.

A lot of work is being done, and it is all paid for by the people who live in Delfland. So for the water board of Delfland it was important to build an SEC that explains our main task to the people in our own area. We want them to understand what Delfland does to keep their feet dry. For this we built a mobile exhibit on our drainage system. An exhibit for Delflanders: it is about their region, it's about the new DSS, the mills and pumping stations and canals in their own vicinity. Because what we have learned is that, no matter how small a country we are, no matter how big the impact of a possible flood in Rotterdam, people in other parts of Holland will be hardly interested.

This exhibit is a mobile one. It was first presented at the opening of the RDM Campus in Rotterdam where the water management course of the HRO has found a new home. Then it was at the Science Center of the Technical University of Delft and the past three months it has been on display at the visitors' center of the Maeslantbarrier. Delfland also uses it at congresses and events where decision makers and the Delfland public are. The exhibit can be borrowed by schools, museums and educational institutes in Delfland.

Since in WP3 we have agreed on the fact that SEC's must function as hubs in the international capacity building program Delfland presents the Keringhuis in Hoek van Holland as its second SEC. Kering is the Dutch word for barrier and the Keringhuis is the visitors center of the Maeslant barrier. The Maeslant barrier was established between 1989 and 1997 in the Nieuwe Waterweg in Hoek van Holland. It is part of the Deltaworks. The Keringhuis was built to inform people about the barrier during its realization. The center is still there because it is annually visited by over 60.000 people from all over the world.

This year the Keringhuis is currently being updated. The entire exhibition was up till now focused on the realization of the barrier itself. Now it is getting a new focus: the new Dutch Deltaprogramm. The heart of the exhibition is a square where visitors can experience the effects of climate change. They can open big tabs to simulate a flood, they can open big heaters or blowers and everything they do is being translated into consequences for the area, possible measurements and their drawbacks.

Next to this square, visitors can walk through a climate "mind set." This mind set starts in a 1953 living room and takes the visitors from the flood disaster in Zeeland that

occurred then to the challenges we are now facing. For schools the Keringhuis will offer lessons on flood risks and the possible measurements. Outside a water playground is being realized where students are challenged to keep their area dry by using pumping stations, barriers, retention basins and altering streams. Next to all of this there is room for temporary exhibitions. The new and improved Keringhuis will be opened this September.

Integrating education, collaboration and research in teaching methods – A Swedish concept

Magnus Johansson, Max Hansson, Lars Nyberg, Emelie Hindersson

Centre for Climate and Safety, Karlstad University, SE-651 88 Karlstad Corresponding author: Magnus.Johansson@kau.se

The foundation of Centre for Climate and Safety at Karlstad University was preceded by an inquiry among stakeholders at local, regional and national level in Sweden. The resulting investigation made a strong point of the need for increased knowledge about the consequences of climate-related hazards and on how vulnerabilities in society towards these threats can be handled.

Demands were put forward on cross-sectional and interdisciplinary approaches, involving new working methods where scientists and stakeholders outside the academy could interact (fig. 1). This short text describes one activity where further education for water managers has been put together in a way that, in some respect, meets up with these demands.

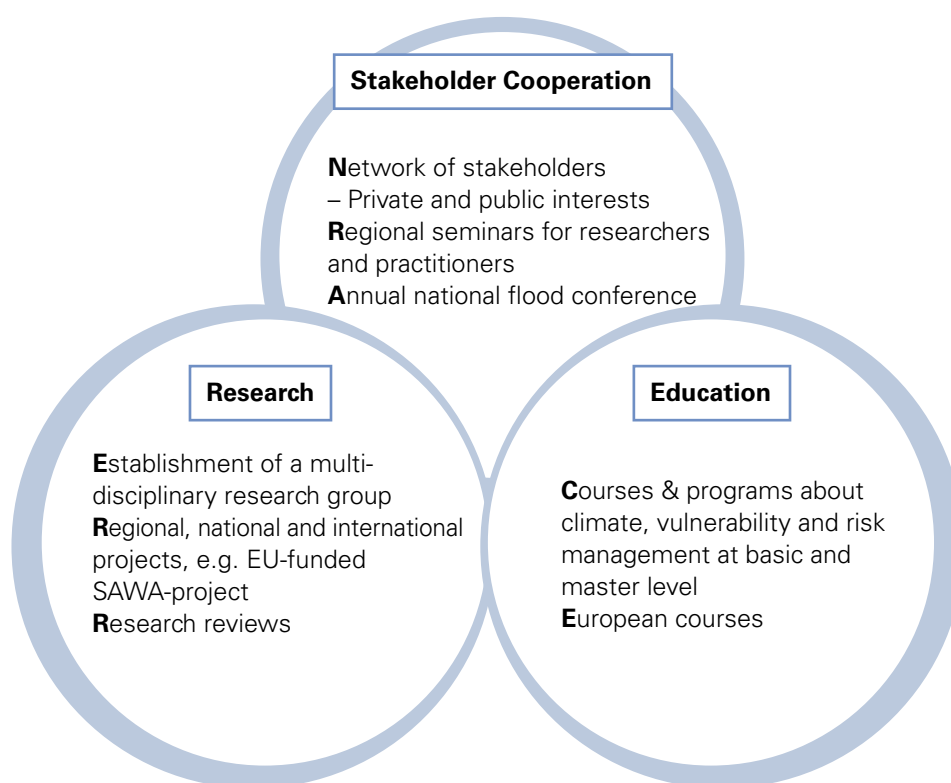

Fig 1. The three main working areas at the Centre for Climate and Safety.

Openness and close collaboration with society are words quite commonly used in visions and goals at many universities. They are intended to be natural parts in education and research. Results and experiences from research are procured in university courses to students, but the knowledge held by students are more seldom viewed upon as interesting from a research perspective. Evidently, that depends on the students possible professional background in correlation with the course

theme, but in the case of performing further educational training, e.g. for managers within climate-related risks, like flooding, it is highly relevant. In our approach we have regarded education, collaboration and research as integral parts and seek a form where one can draw benefits from participation in all directions regardless if you are student or teacher. We call it the IntECR concept (integrated education, collaboration and research).

The IntECR concept

During the period 2008–2010 we have run two different university courses with the same formula: “Lake Vänern and the climate, 15 ECTS” and “Lake Mälaren and future climate, 10 ECTS”. Main theme for both courses has been climate change impact on flooding and risk management. Lake Vänern is the largest lake within the EU and Lake Mälaren is second in order in Sweden, with Stockholm at its outflow. Students have been people working with climate adaptation and/or flood related issues in different sectors and levels, as well as students in their ending of education within e.g. social planning, environmental studies and societal safety.

The carrying idea in this concept is to bring academy and stakeholders together to foster interaction. Since the law-bounded liabilities and management are at municipality level, we found it natural to move the classroom out from the academy to the municipality. The courses have been given on distance using e-learning techniques, but with 5–7 meetings placed at selected cities around the two lakes Vänern and Mälaren respectively. The meetings are the central core in the courses. Each meeting takes one day and consists of lectures, discussions, study visits and field excursion. There are different topics in focus on each meeting with invited experts from central authorities, the academy or private sector. On each occasion water managers, safety officers and societal planners, working at the visited municipality, are encouraged to participate and contribute with their local perspective. The day ends with study visits and field excursion, usually lead by people from the municipality. At the end of the course the students have received local perspectives and practices from several cities and can reflect on similarities and differences on how to manage flood risks in a changing climate.

The arrangement gives many opportunities and advantages in comparison with “regular” campus-based teaching. Overall each meeting offers an arena where actors, existing or future, can meet and exchange knowledge and experiences. The students get the possibility to study real examples on, as in this case, flood management and a direct insight into present planning processes. The municipality officials can raise their problems and planned solutions for discussion in situ with experts from science, central authorities and, sometimes, students with similar professional backgrounds. The scientists and invited experts from central authorities or private sectors can present new facts, theories, methods, ideas, concepts, etc., and discuss them in a local perspective as well as environment. The feedback might give guidance, suggestions and help to problematize new research or identify areas with needs of development.

The IntECR concept is of course applicable to many other subjects of public interest that crosses several disciplines and sectors. The surplus value that arises for all participants, including teachers, can not fully be foreseen, but the potential outcomes are interesting enough to proceed with this concept in future.

SAWA's Academic Network – Joint Forces for a new University program on Flood Risk Management

There are several incentives for education on water management and flood risks. One driving force is to spread the knowledge and experiences from the serious flood events that has occurred in Europe the last decades. Another strong force is the climate change, which causes need for new knowledge and education. A third incentive in the floods area is the EU Flood Directive that was adopted in 2007 and now is implemented in all member states. The directive with its broad perspective on flood risk management (FRM) requires new methods and practices regarding risk mapping and risk-reducing measures, which all in all create needs for education.

There are also specific needs for transnational and European flood education. Many countries in Europe share several characteristics regarding flood hazards and vulnerabilities. The climate, the geography and the societal

structures are fairly similar, which opens for common knowledge development and education. There are also a number of transnational rivers that call for transnational knowledge development and risk management.

Joint education, involving universities from different countries, has different positive effects:

- » bringing knowledge between countries, by exchange of
 - students
 - teachers and researchers
 - professionals
- » shared experiences of flood events
- » shared examples of approaches, strategies and measures taken in different countries

Seven universities are partners in SAWA, each with an own profile in the water management and flood areas:

Universities	Profiles
<p><i>Germany</i> Hamburg University of Technology</p> <p>HafenCity University, Hamburg Leuphana University, Lüneburg</p>	<p>flood management, water engineering, hydrological modeling</p> <p>urban water, architecture and planning</p> <p>sustainable development and flood risks, collaborative planning and modeling</p>
<p><i>Norway</i> Norwegian University of Science and Technology, Trondheim (NTNU)</p>	<p>hydraulic and environmental engineering</p>
<p><i>Scotland</i> Edinburgh University</p> <p>Heriot-Watt University, Edinburgh</p>	<p>environmental engineering, water and wastewater systems, flood retention basins</p> <p>water resources and catchment management, flood management</p>
<p><i>Sweden</i> Karlstad University</p>	<p>climate (esp. flood) risk management, vulnerability studies, learning from flood events</p>

The SAWA education activities are:

- 1 Student and teacher exchange
- 2 Master course, Integrated flood risk management, 15 credits, spring semester 2011
- 3 Planning of masters program in integrated Water and Flood Risk Management, 1–2 years

Master course, Integrated flood risk management

The scope for the course will be flood risk management principles and practices. The relation to neighbouring management perspectives, like water quality and land-use, will be elucidated. There is a need for an integrated approach which has to consider economic, social and ecological aspects of vulnerability and potential risk-reducing measures. Interdisciplinary and transectoral work as well as collaboration among stakeholders is needed. The EU Flood Directive and its requirements will be central in the course content, as well as the interface between the Flood Directive and the Water Framework Directive:

The course is both offered to students already active in masters programs and to professionals that need wider and deeper knowledge about the Flood Directive and flood risk management. Suitable disciplinary background for the participants are for example water management, risk management, environmental science, physical planning, technical infrastructure, contingency planning and education.

The course of 15 credits will be given for the first time between February and May 2011. The learning components will be lectures and seminars (live or web-based), excursions and individual projects. Two excursions are planned to Germany/Netherlands and Sweden/Norway.

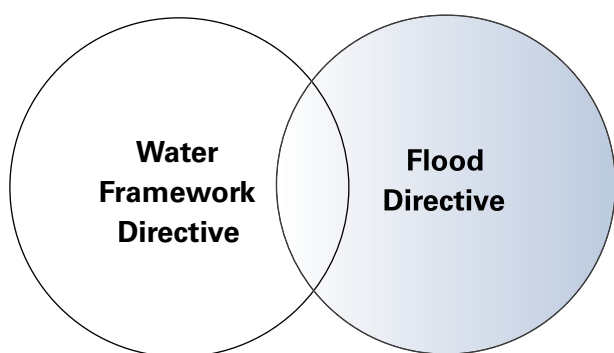

The course content will be structured into four areas:

Governance and legal framework	Impact Assessment
Integrative planning	Adaptive measures

Project Fact Sheets

3-Weir-Regulation

Improvement of inland flood prevention due to a compound weir regulation

Partner Presentation

The LSBG (Landesbetrieb Straßen, Brücken und Gewässer, Agency for Roads, Bridges and Water) is part of the Ministry for Urban Development and Environment (BSU). The BSU is responsible for the implementation of the flood risk management directive in the federal state of Hamburg. In this function the LSBG is also part of the implementation process on the national-wide level for the river basin unit Elbe.

Catchment Area

The Alster is a right tributary of the River Elbe in Northern Germany. It has its source in Schleswig-Holstein and flows roughly southwards and reaches the Elbe in Hamburg. The source of the Alster river is a small bog pool near Henstedt-Ulzburg, approximately 25 km² north of Hamburg. It is 56 km long and has an incline from 31 m to 4 m above sea level. The drainage basin is about 587 km². In the centre of Hamburg the Alster has been canalised. The Alster forms two artificial lakes in the city of Hamburg.

What we do in SAWA

Reducing flood peaks in the catchment areas of the rivers Alster and Ammersbek due to compound weir regulation

Result

The aim of the project '3-Weir-Control' is the improvement of flood prevention in the river Ammersbek and in the middle and lower areas of the river Alster. An automatic adjustable control of three weir systems will reduce flood peaks in the catchment areas of these two rivers which arise in the case of flooding.

The compound weir regulation of the weirs Kupferteich and Mühlenteich in the river Ammersbek and Wohldorfer Schleuse in the river Alster was simulated and programmed with the help of a hydrological rainfall-run-off-model. Upstream located retention areas were also included in the simulation. For rain-fall exposure in these natural as well as urban catchment areas synthetic rainfall events were chosen in different durations and recurring periods.

Due to the 3-weir-control-system, a restoring volume of approximately 172,000 m³ can be activated in the area of Ammersbek and Alster. This is possible due to the water storage area upstream the weir Wohldorfer Schleuse and the Mühlenteich and Kupferteich ponds including the storage basin Brügkamp. They allow a reduction of 15 % of the flood peaks in the river Ammersbek.

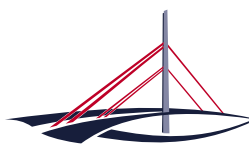

Landesbetrieb
Straßen, Brücken
und Gewässer

In the area of middle Alster, at the lock Fuhlsbüttler Schleuse, the control potential will be approximately more than 5%. This is less as expected. The reason for this is the merging of controlled waves from the river Ammersbek with uncontrolled waves from other catchment areas of upper and middle Alster.

Keywords

Reducing flood peaks, 3-weir-control-system, Alster, hydrological rainfall-run-off-model, SAWA, flood prevention



Position of the weirs on the retention areas

In order to activate the required retention volume, a draining by lowering the weirs is necessary. This always has to occur preliminary to the flood discharge wave. The lowering is automatically controlled by the flow of gauge at Bünningstedt (Ammersbek) and an additional rainfall measurement in the catchment area of the river Ammersbek.

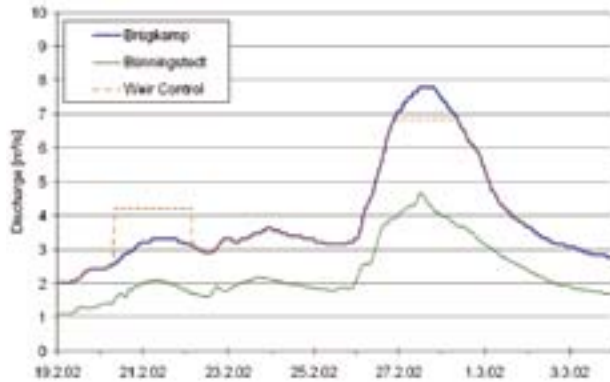

Control Event 27. 2. 2002, Reducing Flood Peaks of 12%

More Information

www.sawa-project.eu

Contact

Jeff Marengwa
 Free and Hanseatic City of Hamburg
 Ministry of Urban Development and Environment
 Agency of Roads, Bridges and Water (LSBG)
 Sachsenkamp 1–3
 20097 Hamburg, Germany
 phone: +49(0)40428262518
 e-mail: Jeff.Marengwa@lsbg.hamburg.de

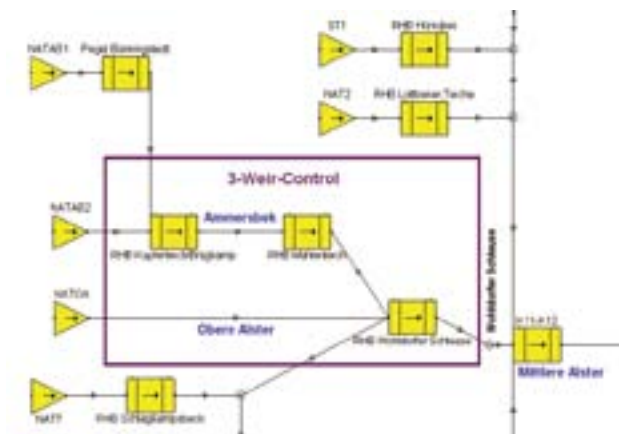

Modules of the Compound Regulation

Hamburg University of Technology



Partner Presentation

Hamburg University of Technology is a young internationally oriented academic education center with strong research profile in water and environmental engineering. The Institute of River & Coastal, part of the Department of Civil and Environmental Engineering, has developed a research expertise in flood risk management for coastal and inland water bodies. With 2 professors, 3 post-doc senior researchers and 14 Ph.D research assistants the Institute is active in several national and international research projects, e.g CORFU, KLIMZUG-Nord, SMAR-TesT and MARE. Relevant for SAWA is their competence in the modeling of river flow, rainfall-runoff processes and flood risk as well as in flood resilience technologies known as non-structural flood measures

Catchment area

The City of Hamburg is drained through three major rivers, the river Wandse, Bille and Alster. With a catchment of 81,60 km², a length of the river of 20 km it is the largest tributary of the river Alster. It is typical for many small urban catchments which have their spring in rather undeveloped or rural areas with hilly landscape. The main part of the catchment is covered by urban areas with high rate of sealing and heavy modified urban water bodies.

What we do in SAWA

Development and application of a participatory planning strategy for the implementation of a Flood Risk Management Plan (FRMP) at the river Wandse. It is based on broad stakeholder involvement making use of the concept of Learning and Action Alliance of the INTERREG project MARE. The strategy is based on a planning cycle subdivided in four main phases

For the support of the planning process the following instruments are developed:

- » Learning tools: Flood Animation Studio and E-Learning Material/E-Lectures
- » Decision support tools: Planner Client and FLORETO

Result

The LAA of the catchment Wandse has been successfully established. After four workshops, which are covering the first phase of the cycle the LAA has developed a strong group dynamics and identity through social learning activities. The capacity to understand risk and its complex system of drivers, pressures and consequences has been built and public stakeholders learnt to read and understand flood hazard and risk maps. The consensus has been found that there is a strong need to mitigate flood risk especially regarding the climate change and urban growth projections.

Within the second half of SAWA the LAA will continue with learning about the impact of ecological measures on flood attenuation and the possibilities of flood resilience measures to reduce the consequences of flood. With this new knowledge the stakeholders will experiment through developing own alternatives to minimize the flood risk taking into account urban growth and climate change.

Keywords

Flood risk management planning, governance, participatory planning, Learning and Action Alliance, decision support and learning tools, integrative planning

Cooperation

Ministry of Urban Development and Environment, Agency of Roads, Bridges and Waters, (LSBG) Hamburg, Germany
HafenCity University Hamburg, Department of Civil Engineering, Hamburg Germany

More Information and Contact:

<http://www.wandse.sawa-project.eu>
Prof. Dr- Ing Erik Pasche, Natasa Manojlovic, Institute of River&Coastal Engineering, TUHH, Denickestraße 22, 21073 Hamburg, Germany
phone: +49 40/4 28 78 37 61
e-mail: pasche@tu-harburg.de,
natasa.manojlovic@tuh-harburg.de



Development of social competences within the

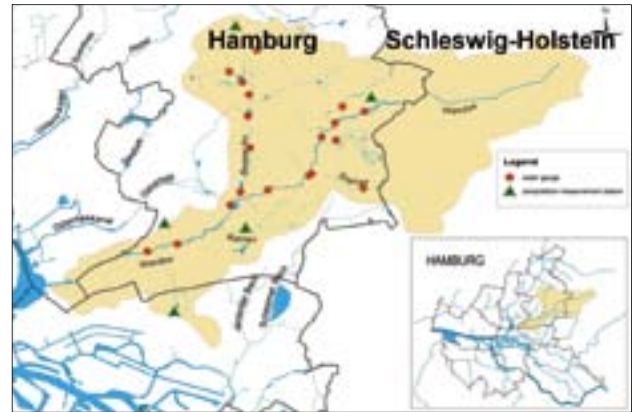

Catchment of river



Assessment of flood risk on site



Learning and Action Cycle of FRMP-Wandse

Leuphana University of Lüneburg



Partner Presentation

Our working group for SAWA directed by Mariele Evers (Ph.D, Professor for Sustainable Landscape Development) consists of two environmental scientists, Philipp Arndt and Julia Mussbach, and Aklilu Teklesadik, hydrologist. We are working on instruments and concepts for sustainable landscape development stressing on water related subjects. Our research and working fields cover integrated water resource management, integrated river basin management, flood risk management, environmental and spatial planning, socio-technical tools for planning, decision support processes and participation. We are part of the department of Sustainability Sciences at Leuphana University of Lüneburg in Germany.

Catchment area

Within SAWA we focus on the catchment of the River Ilmenau (ca. 3.000 km²), situated in Northern Germany (Lower Saxony) in the River basin of river Elbe. The river is a direct tributary to downstream part of the Elbe.



Canalized part of River Ilmenau entering the River Elbe South of Hamburg

Due to its natural shape and the occurrence of protected species and habitats large parts of the river system of Ilmenau are designated as nature protection areas and Flora-Fauna-Habitat regions as part of the European NATURA 2000 network.

The catchment is dominated by agricultural (55%) and forested land (33%) use. The main urban centre is the city of Lüneburg (82.000 inhabitants) which is located at the river Ilmenau and prone to flood risk. Downstream part of the flood prone area can also be influenced by tides from the river Elbe. The challenge in the Ilmenau region is the integration of goals concerning reducing flood risk, increasing water and river structure quality, insure the protection of certain habitats and species and providing space for building development in a growing city.



Natural part of River Ilmenau upstream Lüneburg during winter flood

What we do in SAWA

Within SAWA we work on an integrated river basin management plan (IRBMP). Our main objective is to (1) to identify the flood risk characteristics of river Ilmenau and its catchment and (2) compile the different land use requirements and development proposal of sectoral planning institutions (e.g. management plans for Water Framework Directive, FFH-Directive as well as land use planning aspects) in order to analyse and visualise and to identify synergies and potential conflicts.

By means of stakeholder involvement we are going to develop a measure concept which leads to a prioritization of measures and a targeted application of instruments and resources. Therefore we developed a method for landscape analysis and a catalogue of adaptive measurements which includes also information on implications between each other and potential instruments for implementation. The IRBMP will serve as an important step towards a Flood Risk Management Plan for the river catchment of the river Ilmenau.

Result

Within the described context of setting up the Integrated River Basin Management plan we will carry out

- » GIS-based spatial analysis to identify the flood relevant areas in the catchment,
- » Set-up of a catalogue of measures for preventive flood risk management,
- » Hydraulic modeling of restoration scenarios for some river stretches,
- » Development of a web-based platform (based on Open Geographic Consortium standards) to integrate different information levels and to visualize potential development scenarios for decision makers
- » Initiation of a participation processes together with stakeholders (expert discussions, workshops etc.).

Keywords

Integrated River Basin Management Plan, Adaptive flood risk measures, Synergies between WFD and FD, stakeholder involvement, cross-sectoral (data and information) integration, improve of inter-administrative collaboration,

Cooperation

We are linked with the main regional authorities such as counties (Lueneburg, Harburg, Uelzen), and the regional and federal agencies for water management (NLWK, WSA Lauenburg)

More information

<http://www.leuphana.de/mariele-evers/forschung-projekte/strategic-alliance-for-integrated-water-management-actions.html>

Contact

Mariele Evers (Ph.D, Professor)
 Leuphana University of Lueneburg, Scharnhorststrasse 1
 D-21335 Lueneburg,
 phone: +49 4131/6 77 28 41
 e-mail: evers@uni.leuphana.de

Agriculture Chamber of Lower Saxony



Partner Presentation

Farmers and forest owners, agricultural, horticultural and forest entrepreneur, countrywomen, employers and employees in all green professions, all have an interest to work with the Chamber of Agriculture Lower Saxony as an actor in the rural areas of Lower Saxony and Europe. Our topics of the Chamber are the life, work and training of people in agriculture, forestry and horticulture in rural areas.

Catchment area

Our activities take place in catchment of River Ilmenau and River Elbe in Lower-Saxony. The Region of the lower Elbe, a socio-economic area and cultural landscape, formed and highly influenced by water will be clearly affected by climate change. An increase in extreme weather conditions (e.g. high rainfall within short periods of time, alternating with increasingly long dry periods) will cumulate in extreme high and low water situations with the well known negative consequences considering population, agriculture, shipping and biodiversity. Especially affected by extreme weather conditions will be agricultural land use in the floodplain of the river Elbe. The spatial development in the catchment, and especially rural planning and design, must take greater account of the needs for good water management. Residential areas, agricultural estates, or nature conservation areas, all systems have to be designed to ensure the discharge and temporary retention of precipitation.

What we do in SAWA

The flood event in 2002 at the river Elbe required serious logistical challenges for emergency organisations. In SAWA we will develop recommended procedures to evacuate livestock in a model region (Amt Neuhaus). In literature and publications you can find some instructions for evacuation of pets from flooded areas. But you can find less instructions how to evacuate livestock from

farms in terms of inundations. Livestock evacuation from farms affected by flood events would pose serious logistical challenges for emergency organisations. The flood event in 2002 at the river Elbe required serious logistical challenges for emergency organisations. In SAWA we will develop recommended procedures to evacuate livestock in a model region (Amt Neuhaus). Therefore we model the estimated time and resources required to evacuate livestock (e.g. dairy cattle) during a flood. It would take a number of livestock truck and trailer units to evacuate a number of cows in a few days. It is therefore recommended that small-scale livestock evacuation- and relocation- plans should be considered in flood risk management plans.

Due to the large logistical requirements of livestock evacuation a FRMP would require the coordinates and level of the farm, type and number of livestock to calculate livestock evacuation transport units, and capacity of farms in surrounding regions to house additional livestock. In SAWA we are developing a pilot livestock evacuation plan to implement into a FRMP.

In SAWA we want to implement measures to minimize inundation caused damage for farmer. Therefore we need creative and innovative solutions in combining urban planning and design with water management, flood control, prevention and water retention. We want to develop action plans for an early-warning-system to evacuate livestock and to minimize flood caused damage for farmer (also on farmland by pollution).

Left: River Elbe
Right: Pumpig Station





Left: Dike Sheep, Right Stakeholder

Result

Impact analysis of dike reallocation is done.

At the river Sude restoration of natural geo-morphological structures in the river bed and dike reallocation for nature conservation has been suggested by the local nature conservation board. The relocation of the dike results in larger flooding space for the river and will help to fulfil the goals of WFD, FD and Habitats Directive Nature 2000. Though farmers will lose arable land and sufficient communication will be essential. We did an evaluation of the impacts of dike reallocation to the resident farmer. We made for one farm at the river Sude an investigation on the potential financial loss due to dike relocation. The analysis was done in three steps. First: Identification of stakeholders and relevant parties. Face to face interviews with stakeholder. Second: Analysis and presentation of the economic affect to the farmer. Based on competitive strategies, logistical strategies and ecological concerns of businesses we produced a technical paper (German). Third: Workshops and meetings with farmer and relevant stakeholders to renegotiate the planned dike-line. As a result of the renegotiation the responsible boards offered an alternative dike-line. Discussion is still going on.

In cooperation with the Ministry of Agriculture of Lower Saxony we are making a field study on "Utilization of grass silage from Elbe flood plains in fermentation plants". First results have been implemented in the common recommendations of grassland in Elbe floodplains by Federal States Lower Saxony, Mecklenburg-West Pomerania, Saxony-Anhalt and Schleswig-Holstein.

<http://www.lwk-niedersachsen.de/index.cfm/portal/6/nav/203/article/14245.html>

Keywords

Early warning system, evacuation, livestock, farmland, measures, rural planning, agriculture, flood prevention, integrated water management, WFD

Cooperation

The Agriculture Chamber of Lower Saxony is very well cross-linked with the different levels of government. Presentation of SAWA impacts and activities to the Ministry of Agriculture and to other relevant authorities (municipalities, nature conservation boards etc.) ensure horizontal and vertical participation. Common workshops with Leuphana University and stakeholder. Geographical cooperation with projects LABEL (INTERREG Central Europ), AQUARIUS (INTERREG North Sea) and KLIMZUG-NORD project. <http://klimzug-nord.de/>

More information

Flood risk management need to be coordinated with the ecological river basin management of the EU Water Framework Directive leading to an integrative river basin management in which the two processes benefits from the mutual potential for synergies. Designing, operating and managing flood retention structures can cause problems for farmer. E.g.: Loss of arable land by dike reallocation. Using synergies of FD and WFD will reduce conflicts in spatial planning and reduce agricultural land loss. To achieve these goals, SAWA is very close connected to the INTERREG IVB project AQUARIUS <http://www.aquarius-nsr.eu/Aquarius.htm>

The close cooperation with the LABEL project ensures additional transnational expert exchange. The transnational goals of the project LABEL are of great importance to the Elbe river basin and to our national pilot (located in the Elbe river basin). The development of recommendations for the implementation of flood risk maps in spatial planning, taking into account the pollution problem, has international importance. To achieve these results we are involved in the processing of LABEL to get synergies with SAWA. <http://www.label-eu.eu/>

Contact

Agriculture Chamber of Lower Saxony
Monika v. Haaren, Bezirksstelle Uelzen
Wilhelm-Seedorf-Straße 3, D-29525 Uelzen.
phone: (+49)581 8073 135
e-mail: monika.vonhaaren@lwk-niedersachsen.de

Waterschap Hunze en Aa's, The Netherlands

Partner presentation

The Waterschap Hunze en Aa's is the regional water authority in North East of the Netherlands.

We manage the quantity and quality aspects of our water system. This means maintenance of small rivers, canals, dikes and pumping station and purification plants. We are responsible for implementation of most of the regional measures for the Water Framework Directive (WFD) and the Flood directive (FD).

Catchment area of Waterschap Hunze and Aa's

In the West of our catchment area we have a low plateau formed of glacial sediments. Here we have an old landscape with a lot of nature reserves and free flowing small rivers. It lies 5–20 m above sea level. The middle part of our area is a man made landscape. It is a former high bog more that is completed dug away. Today it is a flat sandy agricultural land with a dense wet infrastructure of artificial ditches and canals. The water level is regulated by weirs and during summer a lot of Rhine water is pumped up to the area.

The eastern part of our area is flat agricultural land on clay. It is also man made as the land is reclaimed from the Sea. It lies between 1 and 2 m below sea level and the water level is regulated by weirs and pumping stations.

The water of the first two area flows into a big canal system that has a water level nearly on sea level. These canals lie in elevation above the land level between dikes and flow through the low eastern part and discharge during low tide by gravity to the sea. Our main flooding risk come from the sea defences that have a standard safety of 1/4000 year and the dikes along the main canals that have a safety standard of 1/100 to 1/1000.

Next to dikes and pumping station our most important measures to reduce flood risk are flood polders along the main canals. In areas upstream of the main canal system we develop measures for water retention. In areas with weirs these measures are artificial (raising weirs to keep the water upstream). Along the small rivers water retention is preferably realized by river re-meandering (for the WFD) in combination flood plan restoration. In this way the river valleys inundate more frequent and store a lot of water.

We have done several studies on flood risk reduction along the main canal system in 2002–2004. This resulted in a Flood Risk Management Plan (FRMP). For the FD we will update these studies and include the effect of sea level rise in it.

What we do in SAWA.

In SAWA we have three sub projects.

DSS

In one we work on the improvement of a Decision Support System (DSS). This DSS is based on a hydraulic model of the main canals system and is used during extreme wet period to support decisions to open enough flood polders on the right moment. Also the right moment to operate the artificial measures for upstream water retention upstream is based on this DSS.

Blue Lakes

In another sub project we studied the effect peak water storage on the water quality of the lake "Oldambtmeer". This lake is a restored lake that was pumped dry some centuries ago. It has now a size of 800 ha and was filled in 2005 and 2006. It is a part of a new developed landscape of nature and urban areas. The whole project was meant as an economic impulse for the economic rather marginal region. The lake is a water body for the WFD. To study the effect of storage on the water quality a model has been developed for the water quantity, water quality and water ecology of the lake. As a result we refined our normal water level management in the lake and we decided what measures are needed to reduce the negative effects of water storage on the water quality. The most important measure was to build a water outlet close to the point where the peak water storage comes into the lake. In this way the water from the main canals, that has a low quality, is not transported through the whole lake. So it does not affect the water quality of the whole lake.

The process to realize river restoration (Achterste Diep)

The third sub-projects deals with the process to realize flood plain restoration in agricultural areas. In areas where the small rivers flow through nature reserves, re-meandering and flood plain restoration is not complicated. It is only a matter of raising enough funds for the required ground work. But in agricultural areas it is very hard to get support for river restoration and it can become extremely expensive. In this SAWA sub project we start a process to find a common approach together with the direct stakeholders like farmers and the in-direct stakeholders like the municipality, the water board and the province. Crucial is to find new economic interesting land use combinations with the present land owners or with new investors. In the SAWA project proposal we indicated the area of the small river "Achterste Diep" Here we just started the dialog with the stakeholders involved. In a nearby small river "Pagediep" one year ago an initiative arose between the municipality, the water board and the province to com-



Left: River Pagediep that has to be restored For WFD (re-meandering) and FD (flood plain restoration)

combine investments in new landscape development with economic investments and river restoration. A frame for a new landscape was developed and the idea is to invite farmers or investors from outside to invest in new land use within this landscape frame. In this way we hope to combine a new economic impulse with river restoration. Here the first investors are already buying land. We want to make this Pagediep also part of our SAWA sub project. In this way we built up experience with a new approach to create water retention in restored rivers.

Result

Our main deliverables within SAWA are reports on our new experience gained in the sub projects. Our measures will also be included in the SAWA measure WIKI-database. Next to that we bring in our old experience with FRMP. We do this by writing memos giving presentations and in discussions in the SWA meetings. The planning of the development of a new updated FRMP for our main canals system is depending strongly on national and regional political decisions. That is why we could not include this action in the SAWA proposal. But if we manage to develop an updated FRMP in time, we will bring it in the SWA project. For the DSS a result will be new developed and improved software for a better functioning DSS with a better communication between specialist and decisions makers during extreme wet situations.

Keywords

DSS, river restoration, water retention, stakeholder involvement, combinations with economic development, multi functional land use, combinations with other policy goals.

Cooperation

In our region we work intensively together with other governmental organisations like municipalities and provinces. Our activities with DSS and river restoration are activities that result from the previous Interreg project FLOWS.

More information

For the FD we have close cooperation with the central government (ministry of traffic and water). The guidelines for flood risk maps and FRMP can be found on the website of this ministry ([www.verkeerenwaterstaat.nl/onderwerpen/water/water_en_veiligheid/130_europese_richtlijn overstromingsrisico_s_\(ror\)/](http://www.verkeerenwaterstaat.nl/onderwerpen/water/water_en_veiligheid/130_europese_richtlijn overstromingsrisico_s_(ror)/))

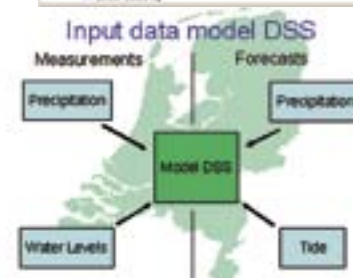
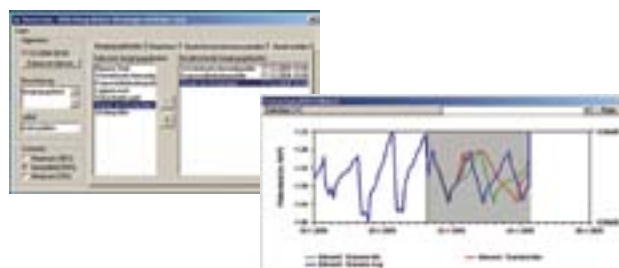

Contact

Jan den Besten, Waterschap Hunze en Aa's,
PB 195, 9640 AD Veendam, The Netherlands
phone: +31.(0)598693602
e-mail: j.den.besten@hunzeenaas.nl

Waterboard of Delfland



Hoogheemraadschap van Delfland

Catchment area

The Delfland region is one of the most densely populated and the most highly industrialised area of the Netherlands. It is located far below sea level. Climate changes affect all aspects of water management in the Delfland region. It affects the risk of decrease of the stability of quays and water quality, and the increased risk of flooding in urban areas and flooding and/or water shortage in rural areas. To guarantee a long-term safe, liveable and sustainable area Delfland needs to protect its region against flooding, water-shortages, etc. Delfland aims to prevent radical measures and high costs in the future, by making sensible investments and taking into account the available surface area.

In the next few years, Delfland plans to develop a climate adaptation strategy with various partners. This strategy starts off with a risk approach, e.g. by calculating both the chance of flooding and its consequences, while improving the quays. Furthermore, Delfland is continually increasing her knowledge of the water system. This is necessary to make educated choices regarding the climate proof development and maintenance of the water system.

What we do in SAWA

The Waterboard of Delfland do participate in WP2 and WP3

WP2 result

With the use of advanced ICT, over 200 water level regulating works can be remotely controlled (end 2011). Secondly, outlet channels can be maintained by a regional control. Finally, ICT offers the possibility to supervise and control the entire region from a central post or remotely from anywhere. The DSS implemented at the Waterboard of Delfland gives the operational controller an overview of the main watersystem status, advice on which pump-stations to engage for managing the expected influx onto the main canal system.

WP3 result

In October 2009 the Delfland mobile SEC on polders, drainage and pumping stations was finalized. The SEC has been displayed at the opening of the RDM Campus in Rotterdam (appr. 4000 visitors), that was performed by his Royal Highness Prins Willem Alexander of the Netherlands.

After this, it has been exhibited in the Science Center of the Technical University of Delft for two months (number of visitors unknown), and at the annual open days of greenery companies at the Westland (appr. 165.000 visitors). Presently the SEC is at the Keringhuis, the visitors center of the Maeslant barrier, where it will be on display till the end of May. 60.000 visitors from all over the world, visit the Keringhuis every year. Delfland is now planning an end-exhibition in the Keringhuis on the entire SAWA project, scheduled for 2011.

Keywords

Watermanagement, faster, better, safer, more effective, simulation models, education, sustainability, collaboration, knowledge

Cooperation

WP2

With in SAWA → WP2 partners

Outside SAWA

Neelen en Schuurman: www.nelen-schuurmans.nl/,

Humig B.V.: www.humiq.com

Vodafone: www.vodafone.nl

WP3

With in SAWA → WP3 partners

Outside SAWA

Hogeschool Rotterdam: www.hogeschool-rotterdam.nl

Buro Kloeg: www.burokloeg.nl

More information

<http://www.hhdelfland.nl/projecten/technische/>

<http://www.hhdelfland.nl/projecten/klimaatverandering/>

Contact

Contact person is Dolf Daal

phone +31 62 7063 870 (mobile)

+31 15 2608 374 (desk)

e-mail ddaal@hhdelfland.nl

Every calamity asks for decisions

A Decision Support System (DSS) is defined as;

“a class of information systems (including but not limited to computerised systems) that support business and organisational decision-making activities. A properly designed DSS is an interactive software-based system intended to help decision makers compile useful information from a combination of raw data, documents, personal knowledge, or business models to identify and solve problems and make decisions.”

The Dutch SAWA partners use DSS's mainly for their surface water management. For example to predict high water levels in their canal systems or to automatically control pumping stations and other water management structures.

These systems can do this because all information needed to make the decisions involved, such as weather forecasts, tidal forecasts, expert knowledge, the possible range of outcomes and real time telemetry is contained within and fed to the system. This information is structured in such a way that a predefined question can be ‚answered‘ by the system. It can do so in a highly consistent manner and (near) real time.

Designing and implementing a DSS can be quite a task. However, the design depends entirely on the questions that need to be answered and the local hydrological situation.

SAWA focuses on a dilemma, flood prevention or mitigation of its effects. In either case, decisions need to be made and therefore a DSS can be used.

The quality of crisis management depends on the information available to base decisions on. A well designed and finetuned DSS can offer a rapid and defendable response under such conditions, for the decision is based on a large amount of pre-organised collective knowledge, experience and (realtime) information.

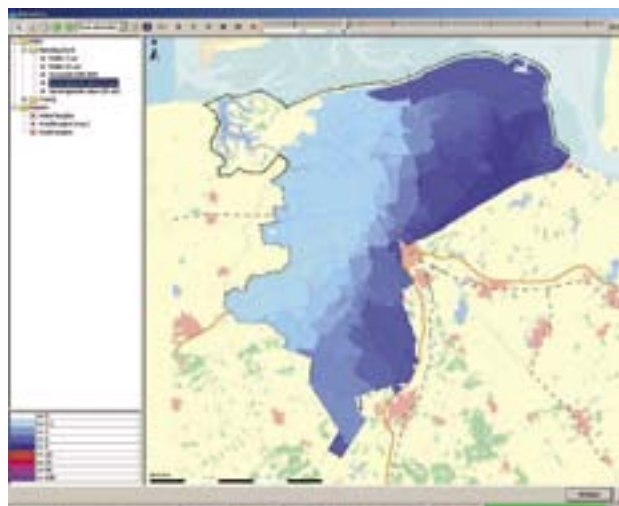

Figuur 1 BOS Delfland. Used for everyday automatic control of main pumping stations

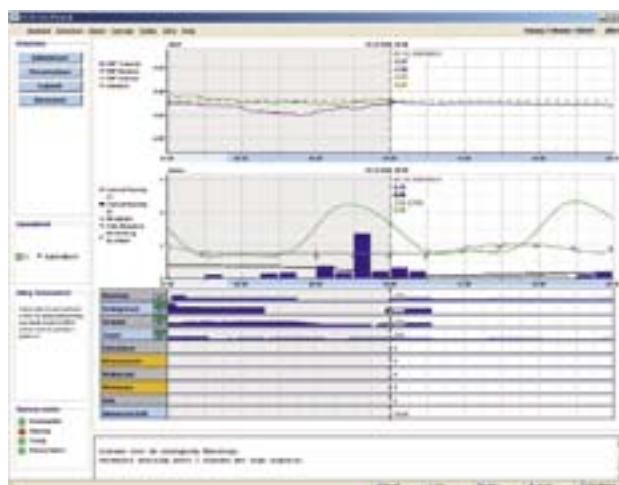

Figuur 2 BOS Noorderzijvest. Used to predict waterlevels in their main water system

Green roofs as measure for urban flood reduction.

The Norwegian Water Resources and Energy Directorate (NVE)



Partner presentation

NVE is a directorate under the Ministry of Petroleum and Energy. NVE's mandate is to ensure an integrated and environmentally sound management of the country's water resources and bears overall responsibility for maintaining national power supplies. The directorate plays a central role in the national flood contingency planning and the prevention of damage caused by inundation and landslides. NVE is involved in research and development in its fields and is the national centre of expertise for hydrology in Norway.

Catchment area – what we do...

When engineers plan the stormwater/sewage system, some of the water will run off on the surface during heavy precipitation. A small increase in rainfall intensity may increase the surface runoff several times. Hence, inundation of houses is likely. E.g., in a part of the city of Fredrikstad a 50 year rain event usually floods 62 houses. With an increase in precipitation of only 15 %, 115 houses will be flooded (Halvor Hardang, Master thesis 2007, www.umb.no). As a result, even small changes in peak runoff may give a significant decrease in flooding.

Using green roofs and other SUDS are a possible way of meeting the requirements from the floods directive in urban areas. Green vegetative roofs are one measure for minimizing the runoff intensities from developed area. This measure is becoming popular in European countries and retention of more than 50 % of the annual precipitation is not unusual. In the NOR3 project a green roof is tested for the cold climate of Norway. An experimental station was set up on an existing garage roof in June 2009, in Oslo at 220 m above sea level. The green roof vegetation is sedum species on a very shallow soil substrate of only 3 cm over a drainage system of 2 cm. Precipitation, runoff from roof with and without vegetation is monitored continuously.

Result

A 40 year rain event (29 mm in 30 min) occurred on the 3rd of July, after a week of warm weather and drought. The green roof gave a reduction in peak runoff of 26 % compared with the reference, a roof without vegetation. The rest of July was wet; total precipitation was 200 mm. For the whole month the runoff from the green roof was 25 % less than the reference roof. Wet green roofs also influence the runoff intensities. In late July the runoff peak after 14 mm rainwater (in 2 hours) was decreased by 48 %.

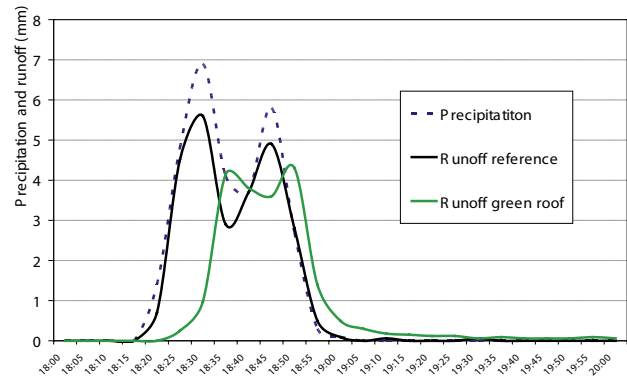

Precipitation (29 mm) and runoff from a roof with no vegetation (reference) and sedum vegetation, shows that the green roof (1) totally retained the first 9 mm, (2) reduced the runoff peak with 26 % and (3) delayed the runoff. The incident happened after one week with drought.

Keywords

Extensive green roof, urban flooding, source control, water management benefits, case study, Nordic climate, retrofit, SUDS.

Cooperation

The NOR3 project gives input to the Wiki catalogue of measures developed in the Wp2 in SAWA. Partners in Germany have good knowledge on the green roof concept. Norwegian partners in the Interreg 4b project MARE is also interested in the green roof project.

Contact

Bent C. Braskerud, P.O.Box 5091 Majorstua,
N-0301 Oslo, Norway.
phone: +4722959595
e-mail: bcb@nve.no



Green vegetative roofs

Rain gardens for urban flood reduction.

The Norwegian Water Resources and Energy Directorate (NVE)



Partner presentation

NVE is a directorate under the Ministry of Petroleum and Energy. NVE's mandate is to ensure an integrated and environmentally sound management of the country's water resources and bears overall responsibility for maintaining national power supplies. The directorate plays a central role in the national flood contingency planning and in preventing damage caused by inundation. NVE is involved in research and development in its fields and is the national centre of expertise for hydrology in Norway.

Catchment area – what we do...

Increased rainfall intensity arising from climate change and increased urbanisation give our cities the same problem – increased stormwater runoff! Hence, inundation of houses will increase unless proper planning is done. Source control, onsite control and slow transport through the catchment may minimise the accumulation of water causing inundation. Sustainable urban drainage systems (SUDS) are a means of handling storm water.

Construction of rain gardens are one measure for minimizing the runoff intensities from developed area. Rain gardens are shallow depressions in the terrain where rainwater from roofs, roads and other sealed surfaces can be stored. The rain gardens are filled with hydrophilic plants. Water entering the gardens is retained for some hours before it infiltrates the soil and recharges the ground water. If needed, purification processes can be included in their construction. The rain gardens are dimensioned according to the required detention time. This measure is popular in USA, e.g., Kansas City plan to implement 10000 raingardens (according to <http://www.stormh2o.com>).

In the NOR3 project several raingardens will be tested for the cold Nordic climate. Two pilot raingardens were constructed the summer 2009 in Oslo and in Melhus municipality. Rain gardens were retrofit in an old developed area with stormwater problems. The rain gardens receive runoff from roofs. The water flux inside the raingardens is monitored continuously.

We are planning 3 more rain gardens this year. Some will receive stormwater from car parks.

Results

We are not yet ready to give recommendations on how rain gardens should be built. A typical Norwegian garden is small. The space consuming design criteria used in the USA, is therefore a challenge. On clay soils and soils with low infiltration capacity, we prepare the soil with a mixture of sand and compost, enabling the use of design criteria for sandy soils (5–7 % of catchment size). Other design criteria's under investigation are: When is drainage necessary? What size is optimal? Which plants are suitable? How can rain gardens be low maintenance without losing the aesthetic value? How can they be designed to be cost effective if soil change and drainage is needed?

Keywords

Rain gardens, urban flooding, source control, water management benefits, case study, Nordic climate, retrofit, SUDS.

Cooperation

The NOR3 project gives input to the Wiki catalogue of measures developed in the Wp2 in SAWA. Through participation in workshops the project gives input to the implementation of the floods directive arranged by the COM working group F. Norwegian partners in the Interreg 4b project MARE and SKINT are also interested in the rain garden project. The project includes involvement from students in engineering and landscape architecture from NTNU (a SAWA partner) and the Univ. of life sciences.

Contact

Bent C. Braskerud, P.O.Box 5091 Majorstua,
N-0301 Oslo, Norway.
phone: +4722959595
e-mail: bcb@nve.no

Photo 1: House owner with new rain garden (Oslo, photo: B.C. Braskerud).

Photo 2: Rain gardens can be retrofit into old developed areas with stormwater problems (Oslo, photo: B.C. Braskerud).

Photo 3: New planted rain garden with pipes for soil water monitoring (Oslo, photo: B.C. Braskerud).



Photo 4: Drainage pipe is needed when the soil has low infiltration capacity. This rain garden is dogged out manually! (Melhus, photo: R.A. Grande)

Photo 5: Some plants are still needed in this new rain garden receiving roof water (Melhus, photo: R.A. Grande).

Rain gardens are drained; however the drainage pipe is narrowed giving an outlet capacity of 4 l/s as maximum outflow.



Climate change and flood risk management in Norway

The Norwegian Water Resources and Energy Directorate (NVE)
The Norwegian Meteorological Institute (met.no)



Partner presentation

NVE is a directorate under the Ministry of Petroleum and Energy. NVE's mandate is to ensure an integrated and environmentally sound management of the country's water resources and bears overall responsibility for maintaining national power supplies. The directorate plays a central role in national flood contingency planning and the prevention of damage caused by inundation and landslides. NVE is involved in research and development in its fields and is the national centre of expertise for hydrology in Norway. Work in the SAWA project is being undertaken in collaboration with the Norwegian Meteorological Institute (met.no).

What we do

The Hydrological Modelling section in NVE is developing projections for likely climate change impacts on hydrology, including flooding, in Norway. Within the SAWA project, we are using ensemble methods to estimate likely changes in the 200-year flood in 115 catchments located throughout Norway. The 200-year flood forms the basis for detailed flood zone maps in Norway, and is therefore an integral part of flood risk assessment. The ensemble method applied here considers several climate scenarios representing different combinations of Global Climate Models (GCMs) and Regional Climate Models (RCMs) from the EU FP6 ENSEMBLES project. The climate scenarios have been downscaled to a 1 by 1 km grid covering Norway, using a technique developed and applied by the Norwegian Meteorological Institute. The hydrological projections for the change in the 200-year flood are presented as probability functions, so that the likelihood of, for example, a 20% increase in the magnitude of flood peaks, can be estimated. The ensemble method also allows the uncertainty in the projections to be estimated and displayed visually.

Results

The results for the projected change in the 200-year flood for catchments in Norway are illustrated in the figure below. The 200-year flood is used for flood zone maps in Norway, and NVE will use this map to delineate regions in Norway most susceptible to an increased flood risk. This information will be made available to communities developing flood risk management plans, including the communities of Trysil and Melhus, which are developing FRMPs within the SAWA project.

Continuing work in the SAWA project will develop further methods for displaying the results and their uncertainties. In selected areas which have a high probability of increased flooding under a future climate, existing hydraulic models will be used to assess the sensitivity of flood inundation to the projected increase.

Keywords

Climate change impacts, 200-year flood, ensemble methods, communicating uncertainty

Cooperation

The hydrological projections for the transboundary Trysil area will be made available to the Swedish Meteorological and Hydrological Institute (SMHI) in conjunction with their work on the River Klara upstream from Lake Vänern within the SAWA project. Collaborative work on the Tana river in Finnmark is also being undertaken with Finland.

More information

Work on the impact of climate change on flooding will also contribute within Norway's national programme for climate change adaptation. Background material for this work has been published (Klima i Norge 2100; Inger Hanssen-Bauer, ed., 2009), and a report on climate change adaptation will be published in Autumn 2010.

Contact

Deborah Lawrence
Hydrological Modelling Section
Norwegian Water Resources and Energy Directorate (NVE)
Postboks 5091, Majorstua, 0301 Oslo NORWAY
phone: +47 22 95 94 07
e-mail: dela@nve.no

Municipality of Melhus, Norway

Partner presentation

Melhus is a municipality with 14600 inhabitants living on an area of 696 km². One of the most important salmon rivers in Norway, Gaula, goes through the area.

Catchment area

Gaula River arises from in the midlands in the center of Norway. This mountainous area stores huge amounts of water as snow. During a summer with a lot rain and low temperatures the snow cover does not melt and so huge capacities of water are still stored here. If now there is a somewhat warmer autumn, maybe connected with also a lot rain, huge amounts of the now available water run down the river. And because of the special topography of Gaula River with its steep river sides, the water level rises very fast. This is very good visible in the graph below. This event was after a couple days of rain and the data was measured at NVE Gaulfossen gauging station. This event shows that the water level almost reached the 10 year flood level in less than 12 hours.

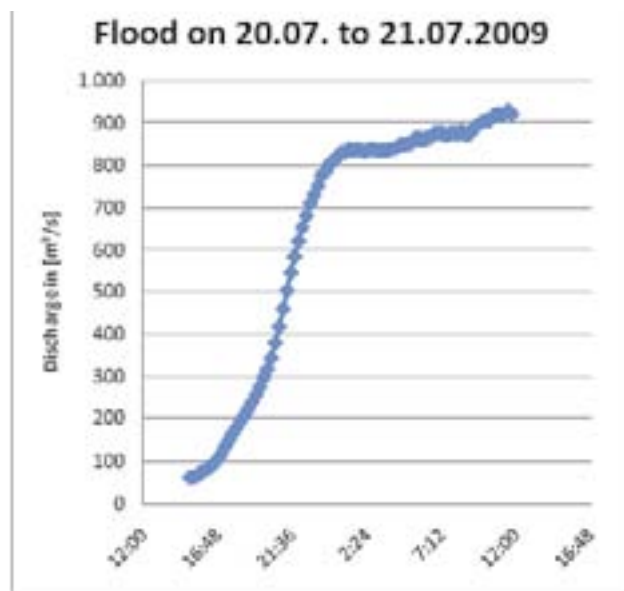

Figure: Small flood in Gaula river in July 2009 (Data form NVEs Gaulfossen gauging station)

Since Gaula River is one of the most important rivers for wild salmon and trout the whole river reach is under protection and river regulations, like hydropower or dams to create reservoirs, which then could store the water and decrease the flood risk, are therefore not allowed. Also a lot of the inlets of small side creeks and bridges passing these had to be rebuilt to allow the fishes a undisturbed pass (according to the water framework directive).

What we do in SAWA

The overall aim with SAWA is to increase security and safety regarding to flood and landslides within the administration in the municipality, and to the public. At the same time it is an aim to conserve the ecological conditions in the main river and the small creeks.

So far in the project we have registered physical intrusions in and along sidecreeks to the main river Gaula. We have also done what this factsheet describes.

Result

The municipality of Melhus has focused on flood risk analysis for an area close to the towncenter. This place, Gimsøya, is expanding and regulated for housing the forthcoming years. With a location next to the river Gaula it's a vulnerable place in case of floods.

The project resulted in several new flood risk maps, showing how the houses and environment is affected by respectively the 10 years, 20 years, 50 years, 100 years, 200 years and 500 years flood. See figure under images. These results are now implemented as an important part of our GIS-system.

Keywords

New flood risk maps
Consequences of flood for houses

Cooperation

This work was driven forward by two students, one from France and one from Germany. They've been working in the municipality from June to September. Their work has been a cooperation project with the University in Trondheim, NTNU, and the municipality of Melhus. In the beginning several meetings were put forward to decide the main focus on the project. In agreement between NTNU and Melhus the work has been based on a flood risk analysis for a popular settled part in the municipality.

Contact

Tove Hellem, Melhus kommune,
Rådhusveien 2, 7224 Melhus
Tove.hellem@melhus.kommune.no

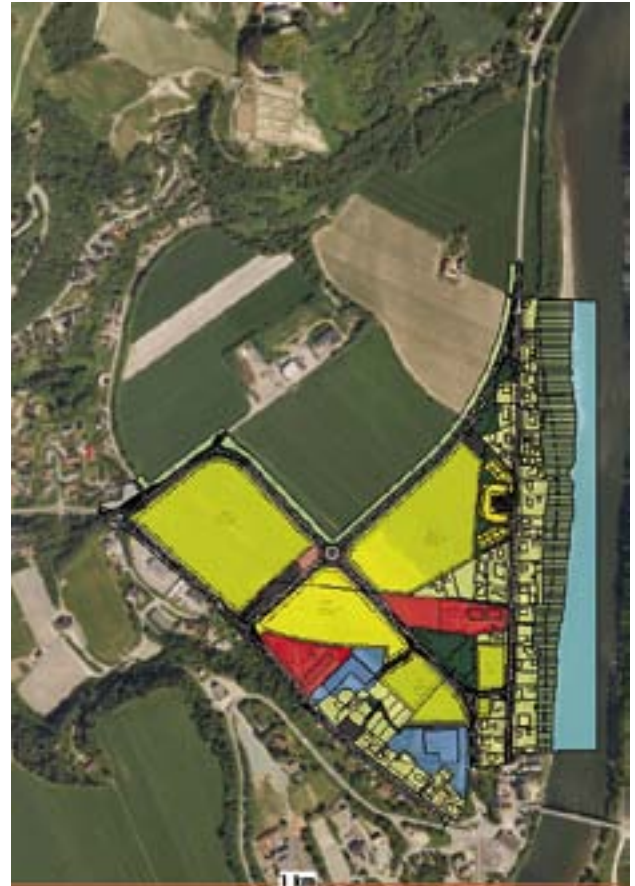

The image on the left side illustrates how the different houses are affected during 200 years flood. The image on the right side show the land use plan which regulate where the municipality wish to build new houses in this area (yellow colour means buildings for housing).

The County Administrative Board of Värmland, Sweden

Partner presentation:

The County Administrative Board of Värmland is a government authority working at regional level linking the government, Parliament and national authorities on the one hand with people and municipalities in the county of Värmland on the other. The Board ensures that decisions taken by the government and Parliament are as effective as possible by providing advice and information, by monitoring and checking that laws and guidelines are complied with and by providing contributions to various kind of activities. Emergency preparedness in the community and land use planning are two important fields of activities.

Catchment area

The pilot catchment area is the region around Lake Vänern in western Sweden. The lake has experienced several flood events in the latest decades. Especially serious was the one that hit the lake and some of its tributaries during the autumn and winter year 2000/2001. Two municipalities in Värmland were among those worst affected. Future climate change is predicted to increase both the total amount of rain and the number and intensity of heavy rains.

The municipalities of Karlstad and Lidköping have been chosen as pilot areas for SAWA. Karlstad is situated in the county of Värmland, Lidköping in the neighbouring county of Västra Götaland. The two County Administrative Boards work in close cooperation.

What we do within SAWA

Preparation for the implementation of the Flood Directive is ongoing in Sweden. The County Administrative Boards will have an important role. We will be directly responsible for producing risk maps and flood risk management plans. Our participation in SAWA will allow us to analyse and experience a possible outcome from the production of such maps and plans and we have decided to do this from a municipal point of view. We will also analyse the possible synergies, benefits and conflicts with the implementation of the Water Framework Directive.

In the chosen pilot areas all Swedish partners will cooperate to produce the maps and plans, to improve knowledge about flooding and sustainable flood risk management, to assess and communicate the effects of climate change and to evaluate and select appropriate adaptive measures. The partners are the two County Administrative Boards, the municipalities of Karlstad and Lidköping (the latter participating without being a formal

SAWA partner), the Centre for Climate and Safety at Karlstad University, the Swedish Geotechnical Institute (SGI) and the Swedish Meteorological and Hydrological Institute (SMHI).

Result

The two main deliveries of our work will be the production of one report on Flood and Risk Mapping according to the Flood Directive in the two pilot areas (published) and one on Flood Risk Management Plans for these pilots (will be finished in 2011). An exhibition about flooding in the catchment area is ongoing at the Väner Museum in Lidköping. It has been produced in cooperation between the two County Administrative Boards and the museum. A seminar was held 14 April for secondary school students (aged 16–17 years) about SAWA and the present and future flood risks in the Lake Vänern catchment area.

We also participate in the arrangement of the mid-term conference in gothenburg 25–27 May 2010.

Keywords

Flood Risk Management Plans, Flood Directive, lake Vänern, Karlstad, Lidköping, climate change, capacity building, adaptive measures

Cooperation

Similar pilot projects to develop good examples of how to implement the different stages of the Flood Directive are carried out in Norway, Germany and the Netherlands. We cooperate closely with SAWA partners from these countries in our work.

More information and contact

More information about the Flood Directive and its implementation in Sweden is available at the Swedish Civil Contingencies Agency's website: <http://www.msb.se/sv/Forebyggande/Naturolyckor/Oversvamning/Oversvamningsdirektivet/> (in Swedish)

For more information about SAWA and the County Administrative Board, please contact:

Johan Mannheimer

County Administrative Board of Värmland,

651 86 Karlstad, Sweden

phone: +46 54 197056

e-mail: johan.mannheimer@lansstyrelsen.se



The Swedish Meteorological and Hydrological Institute



Partner Presentation

The Swedish Meteorological and Hydrological Institute (SMHI) is a government authority subordinate to the Swedish Ministry of the Environment, providing operational services and research in climate, oceanography, meteorology and hydrology. SMHI has around 550 employees in seven departments, including some 80 that work with research.

Catchment area

The pilot catchment area is Lake Vänern in Sweden, with details as below. This is a transboundary basin with its headwaters in Norway, although the majority of the catchment is in Sweden.

Catchment area (incl. lake)	46 880 km ²
Lake area	5 650 km ²
Deepest point	106 m
Lake volume	153 km ³
Regulated volume	9.38 km ³
Mean outflow	550 m ³ /s
Highest known outflow (Jan 2001)	190 m ³ /s

Lake Vänern is the largest lake in the EU (3rd largest lake in Europe). It is a natural lake, but has been regulated since the 1940s. Outflow from Lake Vänern flows into the River Göta Älv, which is the largest river in Sweden and flows through Göteborg, Sweden's second largest city. Lake Vänern and River Göta Älv form a complex system with conflicting stakeholder interests and natural hazards, making it vulnerable to future climate changes. A dam with a controlled spillway is used to regulate the water level in the lake, but during high-flow situations this regulation may not be sufficient to keep the level below acceptable limits. Reducing lake levels by increasing discharge to the River Göta Älv is problematic as this could trigger landslides and cause increased flooding in the vicinity of the river mouth. Conversely, sustained lower water levels in Lake Vänern could have negative consequences, such as disturbed ecosystems, navigation difficulties and decreased hydropower potential.

There are several small cities along the lake that are today at risk for flooding with high lake levels. Furthermore, the shores of Lake Vänern and the downstream River Göta Älv floodplain are under increasing pressure for expanded development of new residential areas. This would ultimately increase potential property and infrastructure damages and put a higher burden on emergency services during flooding events.

What we do in SAWA

SMHI's primary roll in SAWA is to provide information on how climate change is expected to affect the hydrology within the Lake Vänern basin, including water levels in the lake itself and downstream releases to the River Göta Älv. Such information is critical for flood risk planning in the communities around the lake and along the River Göta Älv.

Ongoing work includes the following:

- » Perform climate downscaling using regional climate modelling at varying spatial resolution
- » Provide projected changes to inflow to Lake Vänern from hydrological modelling using a number of different climate projections, i.e. an ensemble approach.
- » Provide changes to water levels in Lake Vänern resulting from the ensemble of projected future inflows.
- » Analyse water levels in Lake Vänern and flow regimes in River Göta Älv resulting from different scenarios of outflow regulation from the lake. This includes changes in duration of high outflows, extra outflow capacity needed to maintain certain water levels, water levels attained if no extra outflow capacity is added, and more.
- » Analyse projected changes in short-term extreme precipitation for use in estimating risks for urban flooding.
- » Analyse the robustness of results from the ensemble of different climate projections used. This includes assessment of using different spatial resolutions in the climate models.
- » More detailed modelling and analysis of River Klarälven, the major tributary to Lake Vänern. This includes a transnational comparison of hydrological results for the Norwegian part of the basin between the different models used by SMHI and NVE.

Result

Work to date has focused on processing, modelling and analysis for changes in lake inflow, water level and extreme precipitation as described above. Results have been reported as below:

Graham, L.P. and Andréasson, J., 2010. En ensembleanalys av klimatpåverkan på Vänern beräknad med de senaste resultaten (An ensemble analysis of climate change impacts to Lake Vänern – latest results, in Swedish). PM (technical memorandum), SMHI, Norrköping, 12 pp.

Olsson, J., Andréasson, J., Graham, L.P., Rosberg, J. and Yang, W., 2010. Using an ensemble of climate projections for simulating recent and near-future hydrological change to Lake Vänern in Sweden. *Tellus*, (submitted).

Yang, W., Andréasson, J., Graham, L.P., Olsson, J., Rosberg, J. and Wetterhall, F., 2010. Distribution-based scaling to improve usability of regional climate model projections for hydrological climate change impacts studies. *Hydrology Research* 41, 211-229.

Keywords

climate change; downscaling; hydrological impacts; flooding; Lake Vänern; River Göta Älv; uncertainty

Cooperation

This work primarily serves other Swedish partners within SAWA and has direct cooperation with the Norwegian Water Resources and Energy Directorate (NVE). We have close cooperation with other Nordic hydrological institutes and major climate modelling centres within Europe, and participate in numerous related national and international projects.

More information and contact

Dr. Phil Graham, SMHI
Folkborgsvägen 1, SE-60176 Norrköping, Sweden
phone: +46-11-4958245
e-mail: phil.graham@smhi.se
www.smhi.se

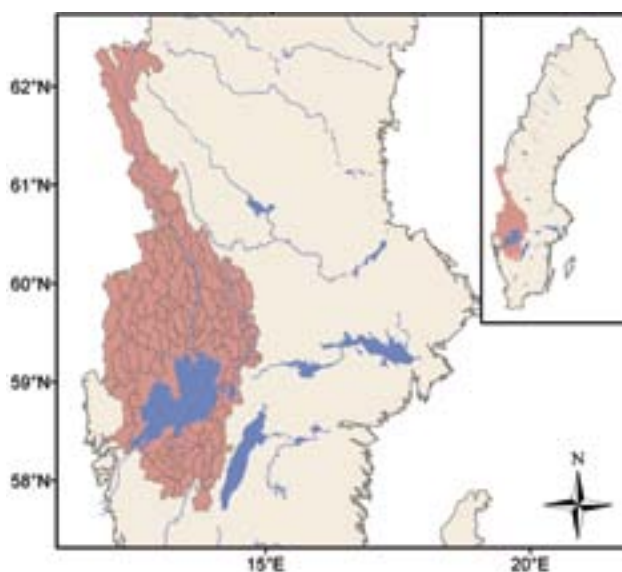

Lake Vänern (photo: Sten Bergström, SMHI).

Lake Vänern catchment area.



The County Administrative Board of Västra Götaland, Sweden



LÄNSSTYRELSEN
VÄSTRA GÖTALANDS LÄN

Partner presentation:

The County Administrative Board of Västra Götaland is a government authority working at regional level linking the government, Parliament and national authorities on the one hand with people and municipalities in the county of Västra Götaland on the other. The County Administrative Board is also authority for the water district of Skagerack and Kattegatt. The Board ensures that decisions taken by the government and Parliament are as effective as possible by providing advice and information, by monitoring and checking that laws and guidelines are complied with and by providing contributions to various kind of activities. Environmental issues, land use planning and work with safety and preparedness issues are important fields of activities.

Catchment area

The pilot catchment area is the region around Lake Vänern in western Sweden, (Catchment area 46 800 km², Area of the lake 5650 km²). The lake has experienced several flood events in the latest decades. Especially serious was the one that hit the lake and some of its tributaries during the autumn and winter year 2000/2001. Two municipalities in Värmland were among those worst affected. Future climate change is predicted to increase both the total amount of rain and the number and intensity of heavy rains.

The municipalities of Karlstad and Lidköping have been chosen as pilot areas for SAWA. Karlstad is situated in the county of Värmland and Lidköping is situated in the county of Västra Götaland. The two County Administrative Boards work in close cooperation with a common projectplan.

What we do within SAWA

Preparation for the implementation of the Flood Directive is ongoing in Sweden. The County Administrative Boards will have an important role. We will be directly responsible for producing risk maps and flood risk management plans. Our participation in SAWA will allow us to analyse and experience a possible outcome from the production of such maps and plans and we have decided to do this from a municipal point of view. We will also analyse the possible synergies, benefits and conflicts with the implementation of the Water Framework Directive.

In the chosen pilot areas all Swedish partners will cooperate to produce the maps and plans, to improve knowledge about flooding and sustainable flood risk management, to assess and communicate the effects of climate change and to evaluate and select appropriate adaptive measures. The partners are the two County Administrative Boards, the municipalities of Karlstad and Lidköping (the latter participating without being a formal SAWA partner), the Centre for Climate and Safety at Karlstad University, the Swedish Geotechnical Institute (SGI) and the Swedish Meteorological and Hydrological Institute (SMHI).

Result

The two main deliveries of our work will be the production of one report on Flood and Risk Mapping according to the Flood Directive in the two pilot areas (published) and one on Flood Risk Management Plans for these pilots (will be finished in 2011). An exhibition about flooding in the catchment area is ongoing at the Vänern Museum in Lidköping. It has been produced in cooperation between the two County Administrative Boards and the museum. A seminar was held 14 April for secondary school students (aged 16–17 years) about SAWA and the present and future flood risks in the Lake Vänern catchment area.

We also participate in the arrangement of the mid-term conference in Gothenburg 25–27 May 2010.

Keywords

Flood Risk Management Plans, Flood Directive, lake Vänern, Karlstad, Lidköping, climate change, capacity building, adaptive measures

Cooperation

Similar pilot projects to develop good examples of how to implement the different stages of the Flood Directive are carried out in Norway, Germany and the Netherlands. We cooperate closely with SAWA partners from these countries in our work.

More information and contact

More information about the Flood Directive and its implementation in Sweden is available at the Swedish Civil Contingencies Agency's website: <http://www.msb.se/sv/Forebyggande/Naturolyckor/Oversvamnning/Oversvamningsdirektivet/> (in Swedish)

For more information about SAWA and the County Administrative Board, please contact:

Susanna Hogdin

County Administrative Board of Västra Götaland
Water Protection Department

S-403 40 Göteborg, Sweden

phone: +46 31 605052

e-mail: Susanna.hogdin@lansstyrelsen.se

www.lansstyrelsen.se/vastragotaland



Karlstad University, Sweden



Partner Presentation:

The Centre for Climate and Safety (CCS) was established at Karlstad University, Sweden, in June 2008. The objective for the centre is to conduct multi-disciplinary research and education within the area of Management of climate risks. A wide approach is chosen, including extensive cooperation with private and public stakeholders from different sectors and levels in the society. The centre has a special focus on floods and its consequences for humans, ecosystems and the society. The understanding of both hazards and vulnerabilities needs integrated efforts from natural and social sciences. Developed methods for systematic learning after disastrous events can give us knowledge about the character of flood events and efficient risk-reducing measures before, during and after events.

The Centre for Climate and Safety is supported by the Swedish Civil Contingencies Agency, the Region of Värmland, the County Administrative Board of Värmland and the Municipality of Karlstad.

Catchment area

The water system of Lake Vänern and the Göta älv River in SW Sweden is our major study area in SAWA. Lake Vänern with its area of 5,500 km² is the largest lake in Sweden and in the European Union. The Göta älv River runs from the lake outlet 90 km down to the sea at Gothenburg. The total catchment area upstream of the river mouth is 51,000 km². Vänern and Göta älv are used for hydropower production, shipping, tourism, fishing, drinking water supply, as waste water recipient, etc. The risk system is complex where flood risks in the lake and in Gothenburg are connected to landslide risks and industrial risks in the river valley, and where the drinking water supply for the Gothenburg region is at stake.

What we do in SAWA

Much of our activities in SAWA have been made in relation to the establishment of a Sustainability Education Centre (SEC). The SEC has undertaken research and studies, education and collaboration with a multitude of external partners.

The flood problems around Lake Vänern have been in focus for some of our studies. A report on the big flood in 2000–2001 was based on existing (scattered) documentation from municipalities, counties, the Government, etc. Another study was a critical analysis of damages and costs for flood scenarios in Lake Vänern, previously presented by a Governmental Inquiry. A third study comprised the indirect effects of a flooded harbour in Lidköping.

Education on climate adaptation and risk management is a key issue for CCS. A special course concept has been developed, to better include capacity building into the learning process. The course on Lake Vänern and the climate was given during 2008/2009. Six education days were arranged in different cities around the lake. Lecturers and experts from local, regional and national level were engaged in full-day seminars. Excursions were also made in every city/region.

The establishment of a national network on flood risk management is one of the collaborative activities for CCS. 15 members among municipalities, regions, national authorities and companies are until now (May 2010) included in the network. Seminars, workshops and similar activities are arranged to get a common understanding and knowledge base.

Result

- » Blumenthal B, 2010. When Lake Vänern was flooded – Description of event and consequences for the flood in 2000–2001. CCS-report 2010:1. In Swedish.
- » Nyberg R, 2010. GIS-applications in flood management – A literature review. CCS-report. In Swedish.
- » Nyberg L et al., 2010. Sustainability aspects of flood risk management – interrelations and challenges. Paper for International Disaster and Risk Conference in Davos in June 2010.
- » Johansson M et al., 2009. Learning lessons from natural disasters – sectorial or holistic perspectives? Geophysical Research Abstracts, vol 11, EGU2009-0, EGU General Assembly 2009 Vienna. (oral presentation)
- » Nyberg L et al., 2009. Influence of flood risk management measures on socio-economic and ecological vulnerabilities in a large water system – a case study of Lake Vänern and the Göta Älv River, Sweden. Geophysical Research Abstracts, vol 11, EGU2009-13263, EGU General Assembly 2009 Vienna. (poster)
- » Johansson M et al., 2009. Evaluating the range of perspectives on lessons-learning from the 2005 storm in Sweden. Society for Risk Analysis (SRA) Europe annual meeting 2009 Karlstad. (oral presentation)
- » University course: Lake Vänern and the climate, 15 credits.
- » Network of 15 members: municipalities, regions, national authorities and companies.
- » One national and one regional conference on climate adaptation and flood risk management. In total 310 participants.

Keywords

flood risk management, vulnerability analyses, GIS, Lake Vänern, education, collaboration

Cooperation

Municipalities: Karlstad, Lidköping, Arvika, Mariestad, Gothenburg, and others

County administrations: Västra Götaland, Värmland, Stockholm and others

National authorities: Swedish Civil Contingencies Agency, Swedish Geotechnical Institute, Swedish Meteorological and Hydrological Institute

Companies: Länsförsäkringar (insurance), Fortum (hydropower), Sweco (consultants), Ramböll (consultants), Skanska (construction)

Research and education: · The SAWA universities (Leuphana University, Hamburg University of Technology, HafenCity University Hamburg, Heriot-Watt University Edinburgh, Edinburgh University, Norwegian University of Science and Technology Trondheim). Uppsala University and the Swedish Defense College.

More information and Contact

For more information about CCS and our activities in SAWA, please contact:

- » Director Lars Nyberg (Assoc. Prof.)
phone: +46-70-2291601
e-mail: lars.nyberg@kau.se
- » Communication officer Kristin Gustafsson
phone: +46-54-7001928
e-mail: kristin.gustafsson@kau.se
- » Centre coordinator Emelie Hindersson
phone: +46-54-7001821
e-mail: emelie.hindersson@kau.se,

Mail address: Centre for Climate and Safety, Karlstad University, S-651 88 Karlstad, Sweden
www.kau.se/ccsenglish



Swedish Geotechnical Institute, SGI

Partner Presentation

The Swedish Geotechnical Institute is a government agency dealing with geotechnical research, information and consultancy. SGI has particular responsibility as a governmental expert body for safety issues relating to landslides and coastal erosion, but the know-how of SGI is available for many sectors of society and comprises land use planning, foundation engineering and the technique of soil reinforcement, slope stability, polluted land, re-use of by-products, field and laboratory investigations and decision bases and support including decision support tools.

Catchment Area

Lake Vänern with its area of 5,500 km² is the largest lake in Sweden and in the European Union. The Göta älv River runs from the lake outlet 90 km down to the sea at Gothenburg. The total catchment area upstream of the river mouth is 51,000 km². Vänern and Göta älv are used for hydropower production, shipping, tourism, fishing, drinking water supply, as waste water recipient, etc. The risk system is complex where flood risks in the lake and in Gothenburg are connected to landslide risks and industrial risks in the river valley, and where the drinking water supply for the Gothenburg region is at stake. There are different interests in relation to floods in Lake Vänern: Firstly, the interest to keep a low and steady water level in the lake to reduce flood risks, in relation to nature conservation interest which advocates large water level amplitudes to maintain the natural variations from the unregulated period before 1937. Secondly, the upstream/downstream risk distribution between flood risks around the lake and a downstream system of landslide risks, industrial risks and water quality risks in the river and in Gothenburg, where most of the economic and social values are located. The landslide risks along the river valley are closely related to fluctuation in water levels and erosion due to high discharge from the lake. Therefore a maximum discharge is decided which, however, increase the flood risks in the lake. Climate scenarios for the 21st century describe substantially increased flood risks for Lake Vänern due to increased amounts of precipitation. The steady sea-level rise cause gradually increasing problems discharge enough water through Göta älv without causing regular flood problems in the lower part of the river valley and in Gothenburg. One proposed measure to reduce the lake flood risks is to secure the slide-prone areas in the river valley with technical constructions.

What do we do in Sawa

SGI has initiated multi criteria analyses/process on expected climate change risks in Lidköping in co-operation with Lidköping Municipality (work 2009- ongoing, meetings 12–13 January 2010 and February 2010). The work has been presented the Swedish SAWA members and is also incorporated in the joint Davos paper by Nyberg, et al, 2010 and some results are also presented at EGU (attached the e-mail as pdf).

We have started a small desk top study on cost benefits regarding land slide prevention for a selected section in central Lidköping, in co-operation with Frida Björckman in Lidköping Municipality (work December 2009- ongoing), meeting 12–13 January 2010. We also aim for doing a desk top assessment of possible flooding due to potential risks of landslides in the Göta älv River. Such an event is regarded as a potential consequence of climate change due to increased tapping and water level fluctuations (see catchment description). We have started compiling a list with adaptation measures in Swedish. The list is based on Pasche et al list (WP2). The aim is to further update it with impacts of the measures on risks on landslides and erosion. The work is initiated at SGI but will be performed in co-operation with primarily Västra Götaland and potential other partners in Sweden and SAWA.

As a final product from SGI we are aiming for to compile the results of the multi criteria analysis/process, the desk study on prevention measures, the adaptation measure list and previous experience to produce a guide that will complement the FD implementation document by Susanna Hogdin et al by also include the risks of landslide and erosion that may occur in events of flooding and heavy water flows.

Result

Up to date:

- » Co-writer in Davos paper by Nyberg, et al, 2010, i.e. "Sustainability aspects of flood risk management - interrelations and challenges, Lars Nyberg¹, Mariele Evers², Yvonne Andersson-Sköld³, Magnus Johansson⁴, Barbara Blumenthal⁵.
- » Some results are also presented at EGU (attached the e-mail as pdf).
- » Presented SAWA at Dipol meeting in Göteborg 2010.
- » Presentations and poster presentations described in previous activity reports (Maritime Conference and Conference organised by Karlstad University).

Keywords

Risk and vulnerability analyses, multi aspect/criteria analysis/process, impacts of flooding on erosion and landslides and vice versa

Cooperation

We have participated in the international SAWA meetings and one international WP 2 meeting in Edinburgh, several/most national meetings with the County administrative board of Värmland and Västra Götaland, Karlstad municipality, Karlstad University and SMHI and Lidköping municipality. Concrete work cooperation on risk and vulnerability analyses with Lidköping municipality and Karlstad University.

More information

Directly related projects: Interreg IVB CPA (Climate proof areas) further information is available on <http://www.climateproofareas.com/>, (Yvonne Andersson-Sköld is to very little extent participating in Dipol in which SGI is a Partner (Gunnel Göransson) National projects: Enhancing cities' capacity to manage vulnerability to climate change, <http://www.cspr.se/start-hogersida/1.186493/AnnualReport2009.pdf>, Effects of societys security work (Effekter av samhällets säkerhetsåtgärder, ESS), <http://www.oru.se/Forskning/Forskningsprojekt/Projekt/HH/ESS-projektet/> SGI: The Göta River vulnerability analysis (responsible for the part regarding consequences of landslides), http://www.swedgeo.se/templates/SGIStandardPage___1353.aspx?epslanguage=EN

Contact

Yvonne Andersson-Sköld, PhD, Associate Prof., Swedish Geotechnical Institute, SGI, Dept. Geoplanning and climate change adaptation, Hugo Grauers gata 5 B, SE 412 96 Göteborg
 phone: +46 31 7786564
 mobile: +46 709 730167
 e-mail: yvonne.andersson-skold@swedgeo.se
www.swedgeo.se



Partner Presentation

Darren Unwin, Post Doctoral Research Associate

Catchment Area

Scotland

What we do in SAWA

Our primary focus within SAWA (WP2) is to develop and apply a methodology, to a case study area, which aims to provide a delivery of consensus and evaluation of Flood Risk Management Plans (FRMP). The methodology is derived and expanded from such themes as Game Theory and Social Science and provides a transparent, stable and adaptable information source that may be utilised fully by practitioners from varying sectors within the Flood Risk Management community. Our secondary focus has been to elevate the performance of FRM measures. This has included:

1. Assessing the impacts of population densities, social dynamics (multiple deprivation) and network density upon recorded customer contacts in relation to urban drainage system derived flooding incidents across Scotland and England. This research provides practitioners with a generic 'usable' tool that may be applied as part of an optimised maintenance and economic strategy that is wholly derived from existing inter-related data sources.
2. Understanding how natural and anthropogenic debris is transported through river networks and how it leads to blockages at culverts.
3. An evaluation of how impermeable hardstanding provision in Scotland is managed in the planning and building standards process.

Results: Reaching Consensus in FRMP

The outcome of the research using the methodology derived from Game Theory/Social Science approaches has been the identification of key aspects/impacts of a proposed FRM scheme upon the core values of an 'inclusive' set of stakeholders within the case study area. The identification of the key impacts of the FRMP is a direct result of meaningful stakeholder engagement/mapping that may be integrated fully as part of an on-going strategic decision support exercise. More information can be found on the following social network sites: Facebook: <http://tinyurl.com/FacebookGT> & Twitter: <http://twitter.com/Stakeholder2010>

Results: Sewerage Asset Management

The outcome of the research into 150,000 drainage system customer contacts has been a generic tool that has been applied to a 5 year data recording period for the major cities of Scotland to high degrees of accuracy (> 85%) to identify the key relationships between the parameters of population, contact and network densities and shows that the relationships between complaint and population densities are detached from any social characteristics – a key finding. The results of these and other key research themes have been published and presented at international conferences, namely:

1. Unwin, D. & Arthur, S., (2010), A study of population density effects and demographic profiling, The First IAHR European Congress" (IAHR/Telford Institute), Edinburgh 4 – 6th May 2010.
2. Wallerstein, N. & Arthur, S., (2010), Development of Equations for Prediction of Blockage at Trash Screens, The First IAHR European Congress" (IAHR/Telford Institute), Edinburgh 4 – 6th May 2010.
3. Arthur, S. & Burkhard, R., (2010), Prioritising Sewerage Maintenance using Inferred Sewer Age – A Case Study for Edinburgh, Water Science and Technology, Vol 61, No. 9, 2417-2424.
4. Wallerstein, N.P., Arthur, S. & Sisinngghi, D., (2010), Towards Predicting Flood Risk Associated with Debris at Structures, Proceedings of the IAHR APD conference. Auckland. New Zealand. 21st – 24th March 2010.
5. Wallerstein, N.P., Arthur, S. & Sisinngghi, D., (2009), Relationship Between River Discharge and Debris Blockage at Culverts with Trash Screens. Proceedings of the final conference of COST action C22 Urban Flood Management, Paris, France. 25th – 27th November 2009.
6. Unwin, D., & Arthur, S. (2009), A Proposal to use Game Theory to Enhance Stakeholder Engagement in the Formulation of Catchment Flood Risk Management Plans, Proceedings of the final conference of COST action C22 Urban Flood Management, Paris, France. 25th – 27th November 2009.
7. Evers, M., Geißler, T.R., Nyberg, L. & Arthur, S. (2009), Capacity Building on Sustainable Flood Risk and Water Management – Transnational and Transdisciplinary Activities In The Northsea Region, Proceedings of the final conference of COST action C22 Urban Flood Management, Paris, France. 25th – 27th November 2009.
8. Arthur S. & Burkhard, R. (2009), Correlation between Sewer Age, Customer Complaints and Sewer Grades – A Case Study for Edinburgh, 8th International Conference on Urban Drainage Modelling, Tokyo, Japan; September 2009.

Keywords

Meaningful Stakeholder Engagement, Strategic Decision Support, Consensus Delivery, FRMP Evaluation, Social Dynamics, Optimised Maintenance Strategy.

Cooperation

We are currently inter-linked within SAWA with Hoogheemraadschap van Delfland and Waterschap Noorderzijlvest, both in the Netherlands. Outside of SAWA we are currently inter-linked with Dumfries and Galloway Council (our primary case study partner), the University of Sheffield (SKINT/MARE/Flood Resilient Cities Projects), the School of Mathematics at the University of Edinburgh and the Scottish Government's Building Standards Division.

Contact

Darren Unwin (d.unwin@hw.ac.uk)
Sustainable Water Management Group, School of the Built Environment, Heriot Watt University,
Eh14 4AS, Scotland, U.K.



Agricultural Flooding (Case Study Area)



River Flooding (Case Study Area)

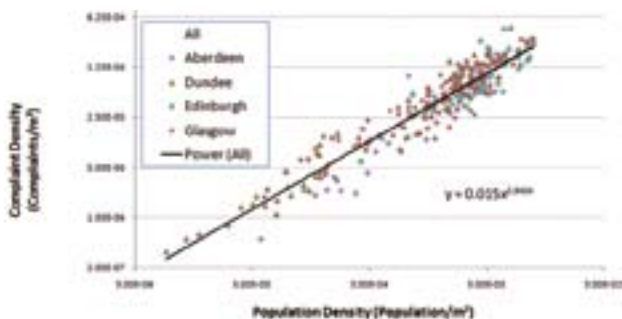

Contact Density (Flooding) v Population Density

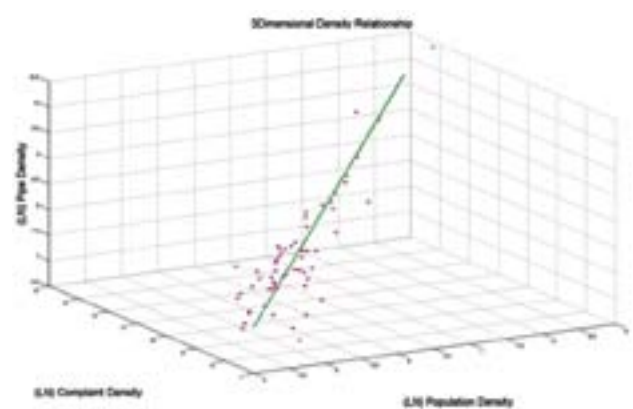

Contact, Population, Dendricity Relationship

Institute for Infrastructure and Environment, The University of Edinburgh



Partner Presentation

The Institute for Infrastructure and Environment at The University of Edinburgh is a leading centre for research into sustainable flood risk management, integrated constructed wetlands and sustainable drainage systems. The University is rated on place 20 with respect to the world ranking list of academic institutions. The School of Engineering, which hosts the Institute, is ranked third in Great Britain.

Dr Miklas Scholz is a Senior Lecturer in Civil and Environmental Engineering and Visiting Professor at Nankai University (Tianjin, China). He is leading the project, and is supported by Mr. William McMinn who is a Research Fellow and PhD student. Moreover, Ms. Qinli Yang, who is also a PhD student, and various temporary workers are also members of the research team.

Catchment Area

The pilot catchment area is the Eastern region of the wider Central Scotland area (Great Britain), which coincides with the eligible area of the Strategic Alliance for Integrated Water Management Actions (SAWA). However, the fieldwork has been expanded to include the Western region of the wider Central Scotland area and Baden (Germany) to allow for more universal validity of the research methodology, which is in development.

The initial fieldwork for SAWA was completed by surveying the wider Central Scotland area between 2008 and 2010. Scotland's rainfall can reach annual mean values of 4750 mm on the hilly West coast, while on the relatively flat East coast, rainfall in an equivalent wet year is typically only 800 mm. This significant variation occurs over distances as short as 130 km. This high variability in rainfall combined with a high population density in the Central Belt can lead to considerable flooding problems. Scotland's existing flood defence infrastructure is largely barrier-based, and many of these defences were constructed prior to adaptation to climate change being identified as a major problem, and are therefore likely to prove unsustainable. The Sustainable Flood Retention Basin (SFRB) concept was therefore been developed as an adaptive measure to support sustainable flood risk management particularly in Europe.

Fig. 1:
Map example showing the application of disjunctive kriging for the variable Managed Maximum Flood Water Volume (m³, exceeding a threshold of 35×10^4 m³).

What We Do within SAWA

The SFRB concept was developed to replace time consuming and expensive existing hydrological and ecological methods with a rapid assessment scheme to identify six SFRB types and non-SFRB. A SFRB is defined as an impoundment or integrated wetland, which has a pre-defined or potential role in flood defence and diffuse pollution control that can be accomplished cost effectively through best management practice, achieving sustainable flood risk management and enhancing sustainable drainage, pollution reduction, biodiversity, green space and recreational opportunities for society. The word sustainable in SFRB means capable of being maintained at a steady level without exhausting natural resources, harming the environment and causing severe ecological damage. The SFRB concept is holistic and inclusive, and is therefore intended to facilitate the use of SFRB within sustainable flood risk management planning.

The Flood Directive has been implemented in Scotland through the Flood Risk Management (Scotland) Act 2009. The act requires that all water bodies and natural features are assessed for their contribution to flood risk management. In Scotland, this represents a significant challenge as there are likely to be more than approximately 30,000 water bodies greater than 10,000 m². The SFRB concept will allow for the utilization of many natural wetlands, dams, reservoirs and some natural lochs for sustainable flood management.

A database of approximately 400 SFRB sites in the wider Central Scotland has been compiled, and is currently undergoing detailed analysis. A guidance manual for the SFRB survey method has been produced and is available on request via m.scholz@ed.ac.uk.

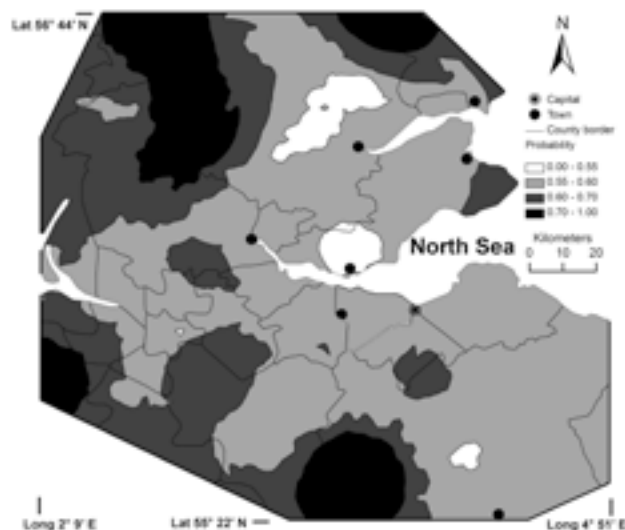



Fig. 2
Study area, administrative boundaries and the identified Sustainable Flood Retention Basins in the wider Central Scotland area (United Kingdom).



Fig. 3
Glenfarg Reservoir (near to Rossie Ochill, County of Perth and Kinross), an example of a Traditional Flood Retention Basin (Sustainable Flood Retention Basin type 2) that is, however, currently used only for drinking water supply purposes (picture taken by Qinli Yang on 20 November 2008).



Fig 4: Hare Myre (2.5 km south-east of Blairgowrie, County of Perth and Kinross), an example of a Natural Flood Retention Wetland (Sustainable Flood Retention Basin type 6) that is predominantly used for environmental protection, recreational and diffuse pollution control purposes (picture taken by Qinli Yang on 7 July 2009).

Results

The project has led to the following output in April 2010:

McMinn W. R., Yang Q. and Scholz M., Classification and Assessment of Water Bodies as Adaptive Structural Measures for Flood Risk Management Planning, *Journal of Environmental Management* (in press).

Robinson M., Scholz M., Bastien N. and Carfrae J., Classification of Different Sustainable Flood Retention Basin (SFRB) Types, *Journal of Environmental Sciences* (in press).

Scholz M. (2009), Classification and Assessment of Water Bodies as Sustainable Adaptive Measures for Flood Risk Management Planning in Response to Climate Change. In I. McLauchlan (Ed.), *Proceedings of the CIWEM Scottish Branch 2009 Symposium "Flood Risk Management in the 21st Century"* (03/11/09), Edinburgh.

Robinson M., Scholz M., Carfrae J. and Bastien N. (2009), Classification and Optimisation of Flood Retention Structures. In *Proceedings on CD of the 13th IWA DIPCON 2009*, 12–15 October 2009, Seoul, Korea.

Yang Q., McMinn W. R. and Scholz M. (2009), Potential Use of Natural Flood Retention Wetlands to Control Diffuse Pollution. In J. M. Bayona and J. Garcia (Eds.), *Proceedings on CD of 3rd Wetland Pollutant Dynamics and Control WETPOL 2009* (20–24/09/09), Barcelona, Spain. ISBN-10: 978-84-692-5587-2. pp. 79–80.

Yang Q., McMinn W. R. and Scholz M. (2009), Potential Use of Natural Flood Retention Wetlands to Control Diffuse Pollution. In *Abstract booklet of SUDSnet 2009 conference* (12–13/11/2009), Coventry, England, UK., pp. 34–35.

Three further journal papers and two conference papers are currently being considered for publication. The key scientific outcomes of all publications are as follows:

- » A data base of 400 water bodies characterized by 40 variables was developed.
- » An SFRB survey methodology was developed to identify key variables.
- » Classification methodologies were used to identify six key SFRB types.
- » A self-organizing map model was used to predict flood control variables.
- » A geostatistical analysis supports flood risk management planning.

Cooperation

The project is part of the trans-national output for the second work package of SAWA, and is linked to the previous European Union project FOWARA.

More Information and Contact

For more information on this and other related projects, please contact Dr Miklas Scholz. Institute for Infrastructure and Environment, School of Engineering, The University of Edinburgh, William Rankine Building, Mayfield Road, The King's Buildings, Edinburgh EH9 3JL, Scotland, United Kingdom.

phone: 0044-131-6506780

e-mail: m.scholz@ed.ac.uk.

Acknowledgements

The Lead Beneficiary would like to thank all those who contributed to the SAWA-Mid-Term Conference. Great appreciation is therefore due to:

Mr. Christoph K pferle from Golder Associates. Christoph K pferle is Project Manager in the SAWA project. I would like to thank him for his leadership role and support to the Lead Beneficiary, as well as for delivering critical inputs and suggestions for the conference program.

The Management Team: Nicole Dr cker, Catrin Hasewinkel, Christoph K pferle, Antje M ller, Susanne Peeger.

The Chairpersons of the sessions at the Conference: Prof. Erik Pasche, Scott Arthur, Ian Hill, Mariele Evers and Lars Nyberg.

Appreciation is also due to the Swedish Host the County Administrative Board of V stra G taland and team who helped to prepare everything for the conference. A special thank goes to Susann Hogdin who made major arrangements for the conference.

A significant factor in the success of the Conference was the support received from the following partners:

- » Ministry of Urban Development and Environment; Agency for Roads, Bridges and Waters, LSBG
- » TU Hamburg-Harburg
- » HafenCity Universit t Hamburg (HCU)
- » LEUPHANA University L neburg, Fakult t Umwelt und Technik
- » Agriculture Chamber of Lower Saxony
- » Province of Flevoland
- » ZZL, Waterschap Zuiderzeeland
- » HEA, Waterschap Hunze en Aa's
- » NZV, Waterschap Noorderzijlvest
- » Waterboard of Delfland
- » NVE, Norwegian Water Resources and Energy Directorate

- » Norwegian University of Science and Technology (NTNU)
- » Melhus Municipality
- » Norwegian Meteorological Institute
- » County Administrative Board of V rmland
- » SMHI (the Swedish Meteorological and Hydrological Institute)
- » County Administrative Board of V stra G taland
- » Karlstad University
- » SGI, Swedish Geotechnical Institute
- » City of Karlstad
- » Heriot-Watt University ; Sustainable Water Management Research Group, School of the Built Environment
- » Institute for Infrastructure and Environment, School of Engineering and Electronics, The University of Edinburgh
- » Golder Associates GmbH, Hamburg

Many thanks to the North Sea Region Program 2007–2013. The Program connects regions from several countries around the North Sea, incorporating policy level planning and the long lasting and tangible effects of projects. These are the foundations of the future transnational projects, which will create added value to partner regions and beyond.

More Information about SAWA and also additional fact sheets can be found on the webpage: www.sawa-project.eu

Jeff Marengwa, SAWA Project Leader



Imprint

Herausgeber und Vertrieb: Freie und Hansestadt Hamburg
Landesbetrieb Straßen, Brücken und Gewässer (LSBG)
Sachsenkamp 1–3
20097 Hamburg
V.i.S.d.P.:
Helga Lemcke-Knoll

Editor: Jeff Marengwa
mit Unterstützung von: Nicole Drücker, Catrin Hasewinkel, Christoph Küpferle,
Antje Müller, Susanne Peeger

Auflage: 1.000 Stück, gedruckt auf mindestens 80 Prozent Altpapier

Stand: Mai 2010

Gestaltung: Hamburgs Agentur, Landesbetrieb Geoinformation und Vermessung

Titelfoto: Bay of Gothenburg, Catrin Hasewinkel

ISSN 1867-7959 (Print)

Die Verfasser sind für den Inhalt der Aufsätze allein verantwortlich. Nachdruck aus dem Inhalt nur mit Genehmigung des Herausgebers gestattet.

Anmerkung zur Verteilung

Diese Druckschrift wird im Rahmen der Öffentlichkeitsarbeit des Senats der Freien und Hansestadt Hamburg herausgegeben. Sie darf weder von Parteien noch von Wahlwerbern oder Wahlhelfern während eines Wahlkampfes zum Zwecke der Wahlwerbung verwendet werden. Dies gilt für Europa-, Bundestags-, Landtags- und Kommunalwahlen. Missbräuchlich ist insbesondere die Verteilung auf Wahlveranstaltungen, an Informationsständen der Parteien sowie das Einlegen, Aufdrucken oder Aufkleben parteipolitischer Information oder Werbemittel. Untersagt ist gleichfalls die Weitergabe an Dritte zum Zwecke der Wahlwerbung. Unabhängig davon, wann, auf welchem Weg und in welcher Anzahl diese Schrift dem Empfänger zugegangen ist, darf sie auch ohne zeitlichen Bezug zu einer bevorstehenden Wahl nicht in einer Weise verwendet werden, die als Parteinahme der Landesregierung zugunsten einzelner politischer Gruppen verstanden werden könnte. Den Parteien ist es jedoch gestattet, die Druckschrift zur Unterrichtung ihrer eigenen Mitglieder zu verwenden.

Mit freundlicher Unterstützung vom

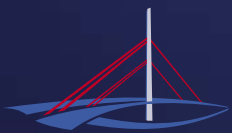

Landesbetrieb
Straßen, Brücken
und Gewässer



Investing in the future by working together for a sustainable and competitive region



EUROPEAN UNION
European Regional
Development Fund